

CHANGING THE LENS (OPEN SPACE TO CORRIDOR)

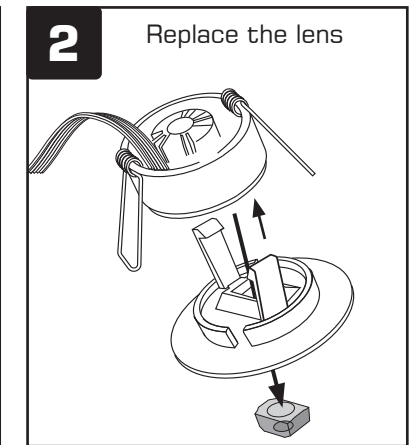
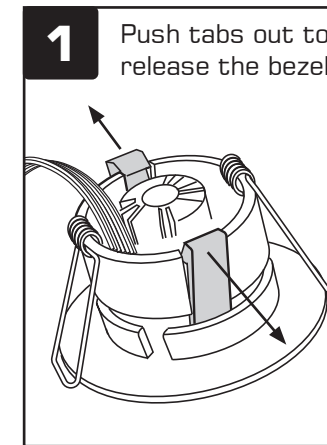

SELF TEST METHOD:

MODE	METHOD FOR MODE	IF	LED INDICATOR STATUS	RESULT
Mains ON	No action needed	No fault	Green (Permanently On)	Green LED
	No action needed	Battery fault	Red (Flashes every 1Hz)	Red LED
Mains Off	No action needed	LED fault	Red (Permanently On)	Red LED
Mains Failure	No action needed Luminaire enters 3 hour emergency mode	Battery OK	Off	

NOTE:

- Mains supply ON, if the black test button is pressed the luminaire will illuminate to test the emergency function.
- Mains supply OFF, if the black test button is pressed the luminaire will turn off in order to conserve battery energy.

ENLITE®

CODE: EMD1

**3 HOUR NON-MAINTAINED POLYCARBONATE
LED EMERGENCY DOWNLIGHT**



IMPORTANT INSTALLATION INFORMATION

- Installation should be carried out by a qualified electrician in accordance with the latest edition of the National wiring regulations.
- Mains supply voltage 220-240V AC 50/60Hz
- Ensure that ALL electrical connections are tight with no loose strands including factory made connections.
- Batteries must be charged for 24 hours to ensure full emergency duration and before testing.
- The battery will recharge normally after a short-circuit battery test.
- A green LED within the module indicates the battery is charging correctly.
- Please note - There is basic insulation between the battery and supply.
- The wiring between supply and the battery circuit is double insulated
- The battery is Lithium 1500mA 3.2V
- The input cable conductor cross sectional area is 0.75mm² -1.5mm²
- To test in emergency mode operate the installation emergency keyswitch or button on the product which will switch off the permanent mains supply to the emergency lighting circuit.
- The emergency lighting will operate from 5°C to 25°C
- When the luminaire no longer meets its rated duration of emergency operation, the battery should be replaced with a battery of the same specification.
- LIVE – (Brown) to Terminal Marked L
NEUTRAL – (Blue) to Terminal Marked N
- **After connecting the mains supply check the following:**
 1. The green charge indicator LED is illuminated. This indicates that the mains supply is present and that the charger circuit is working correctly.
 2. The unit should be left on charge for a minimum of 24 hours before testing the emergency mode.
 3. To simulate normal mains supply failure, operate the key switch (See figure 3 on page 1).
 4. The lamp will now light under emergency conditions.
 5. When the unit no longer meets its rated duration of operation the battery pack must be replaced with a battery of the same type, voltage and Amp-hour rating.

WARRANTY INFORMATION

Environmental Protection (W.E.E.E.) – Enlite's WEEE Reg.No. WEE/BG0130YX (UK Only)



Waste Electrical & Electronic Equipment Regulations (WEEE) requires that any of our products showing this marking (left) must not be disposed of with other household or commercial waste. Enlite does not levy any WEEE disposal charges to its customers for affected WEEE related products. To prevent possible harm to the environment or human health from uncontrolled waste disposal, please separate any such product from other waste types and recycle it responsibly at your local facilities. Check with your Local Authority, Recycling Centre or retailer for recycling advice. If, when you purchased any Enlite product, your supplier included a WEEE disposal fee, you should then contact your supplier for advice on his take back of the product for the correct disposal.

GUARANTEE

This product is guaranteed for a period of 3 years from the date of purchase. The guarantee is invalid in the case of improper use, installation, tampering, and removal of the Q.C. date label, installation in an improper working environment or installation not according to the current edition of the National Wiring Regulations. Should this product fail during the guarantee period it will be replaced free of charge, subject to correct installation and return of the faulty unit. Enlite does not accept responsibility for any installation costs associated with the replacement of this product. This warranty is in addition to the statutory rights in your country of purchase. Enlite reserves the right to alter specifications without prior notice.