

Date	Revision
1.6.2022	2

### Specification

1. Operating environmental temp: 0°C to +35°C.
2. Operating relative humidity: less than 90%.
3. Rated voltage: 220-240V 50/60Hz.
4. Wattage: 3.3W.
5. Conversion time: 1 second.
6. LED:SMT 2835 LED <8.
7. Lumens: 140lm.
8. Emergency duration: more than 180 minutes.
9. Battery installed or replaced:  
LiFe PO4 3.2V 1500mA
10. Fuse installed or replaced 3A 250V
11. Recharge time 24 hours

### Important Information

**We recommend that luminaires are installed by a qualified electrician ensuring the installation complies with current IEE wiring regulations BS7671:2018 & local building control.**

- All tests should be carried out in accordance to EN 50172:2004.
- BELL will not accept responsibility for any claims arising from a poor installation.
- The light source of this luminaire is not replaceable: when the light source reaches end of life, the whole luminaire must be replaced.

### Important User Advice

- Ambient room temperature should not exceed 35°C.
- Ensure that there is adequate free air ventilation around the fitting.
- It may be necessary to uprate your MCBs to allow for increased inrush current.
- Always switch off mains supply before installing.

This product may contain substances that can be hazardous to the environment if not disposed of properly. Electrical and electronic equipment should never be disposed of with general household waste but must be separated for its correct treatment and recovery. Where possible recycle your packaging.



**Read these instructions before installation and retain for future reference**

**This equipment should be installed by a competent electrician**



### Installation:

1. Connect mains supply wiring as follows:



L (Permanent Live) L1 (Switch Live)

2. Power line & battery wires should be connected securely, and all screws fixed.
3. Switch on 220-240V AC supply and check if the green LED indicator illuminates to confirm charging of batteries.
4. The fitting should be simulated to ensure that the fitting work during mains failure.

**Conducting additional manual tests of self-test fittings may significantly reduce battery life.**

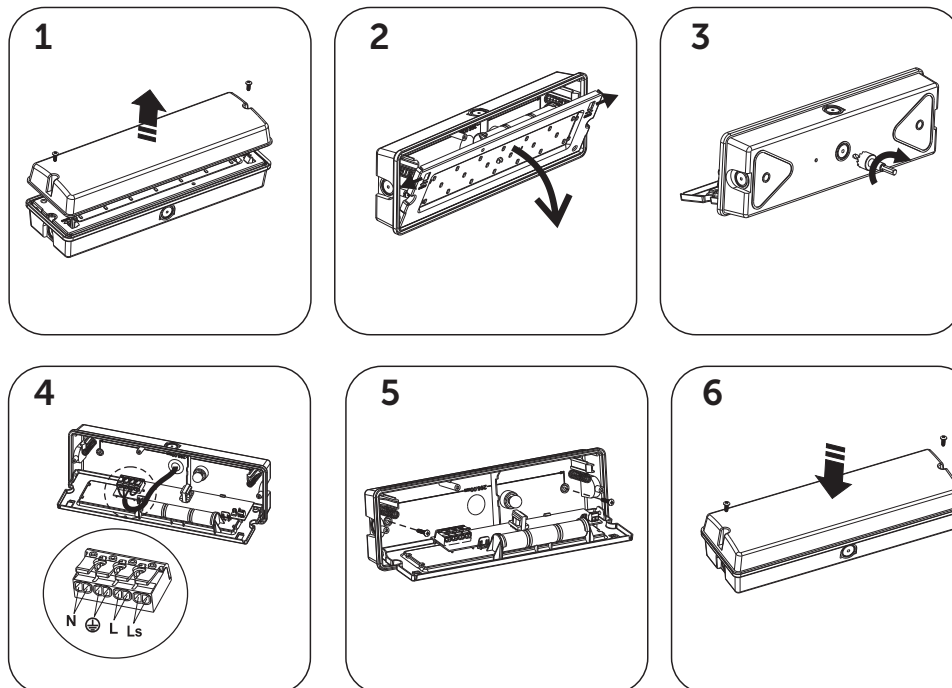

**Technical Helpline +44 (0)1924 893380**

**www.bellighting.co.uk**

British Electric Lamps Ltd, Unit A Foxbridge Way  
Normanton Ind Est, Normanton, West Yorkshire. WF6 1TN

T: +44 (0)1924 893380 F: +44 (0)1924 894320 E: sales@bellighting.co.uk

The test button of the unit has the following functions:

Test Button	Green LED	Status
Press for approx 1 Second	Off	Emergency mode for 1 second
Press for approx 5 Seconds	Slow flash	Function for 30 seconds
Press for approx 7 Seconds	Fast Flash	3 Hour duration test
Press for approx 10 Seconds		End the duration test

Please refer to following chart below for more complete description/fault indication:

Test Button	Green LED	Status
Green solid	Mains on / No fault	
Green flash	Slow flash	Function for 2 minutes
	Fast flash	3 hour duration test
Red flash	1 Flash cycle	Battery fault
	2 Flash cycle	Lamp fault
	3 Flash cycle	Duration test fault

Conducting additional manual tests of self-test fittings may significantly reduce battery life

### Self-Test

Self-Test fittings perform a self-commissioning test at first power on. After charging for 24 hours a full duration test (3 hours) is performed. Initial function and duration tests are randomly generated. They are then performed in accordance with standard requirements (every 30 days for function tests and every 52 weeks for duration tests).

A single bi-colour indicator LED is fitted in all Self-Test products. This LED is clearly visible for manual inspection. It indicates the module status. The LED shows permanent green or flashing green when conditions are normal and flashing red if a fault condition is present

### Function test

A function test is a 2 minutes test that simulates a mains failure and checks the operation of the emergency light source from the battery supply.

The local indicator LED slow flashes green whilst the 2 minutes function test is in progress.

If there is a failure during a function test the local indicator LED changes to a flashing red.

### Duration test

A duration test simulates a mains failure. It also checks the operation of the emergency light source from the battery supply for the rated duration of the module.

The local indicator LED fast flashes green whilst the duration test is in progress.

If there is a failure during a duration test the local indicator LED either changes to flashing red. The battery is required to be fully charged before a duration test can be started.

**Technical Helpline +44 (0)1924 893380**

**www.bellighting.co.uk**

**British Electric Lamps Ltd**  
Unit A Foxbridge Way, Normanton Industrial Estate  
Normanton, West Yorkshire. WF6 1TN

T: +44 (0)1924 893380 F: +44 (0)1924 894320 E: sales@bellighting.co.uk

**www.bellighting.co.uk**