

Commercial PC Wall Bulkhead

Installation instructions for Wall Pack

JCC | a **LEVITON** company

Warnings & Cautions

- It is recommended that luminaires are installed by a qualified electrician to ensure the installation complies with the local current wiring regulations
- Do not install in areas that are exposed to continual running water or prone to flooding. Ensure that the mounting surface is both flat and stable
- These products are designed for connection to a 220-240V~ 50/60Hz supply.
- Any broken or damaged parts should be replaced as soon as possible. JCC will not accept responsibility for claims arising from sub-standard installations
- It may be necessary to upgrade your MCBs to allow for increased inrush current.
- This luminaire is suitable for outdoor use.

INSTALLATION

ENGLISH

Specifications Colour temp: 3000K/4000K Ra: 80

Total circuit wattage	Lumens	LpcW
22W	1500	70

Beam angle: 120°

220-240V~ 50/60Hz Class I ⚡

Figure 1. Mains input

Standard versions

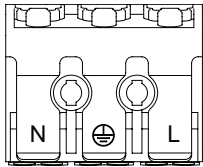

Terminal block must comply to EN 60998-2-1 or EN 60998-2-2

- Read instructions and check that you have all of the tools and accessories required to complete the installation correctly. Isolate power supply before starting the installation.

Installation procedure

1. Remove cover by loosening all screws.
2. Drill mounting holes and insert suitable wall plugs.
3. Prepare the mains input cable for termination. Note that this product is class I and as such must be fitted with an earth connection.
4. Terminate input wiring to the fitting as per Fig. 1.
5. Secure in desired location.
6. Refit the cover and ensure the seal is correctly seated to maintain IP65 rating.
7. Turn on power supply and test for correct operation.

Note - optimum mounting height - 3m

It is the responsibility of the installer to maintain the IP rating when mounting and connecting the mains.

General Maintenance Requirements

This product has no user servicable parts. JCC Lighting Products would recommend that the following maintenance is performed in order to prolong the life of this product: Clean with a damp cloth and dry with a lint free cloth or kitchen towel. Do not use abrasive cleaners.

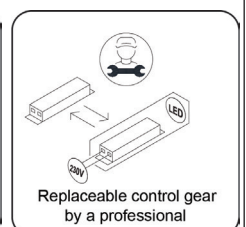
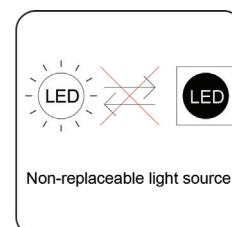

Profile & Dimensions

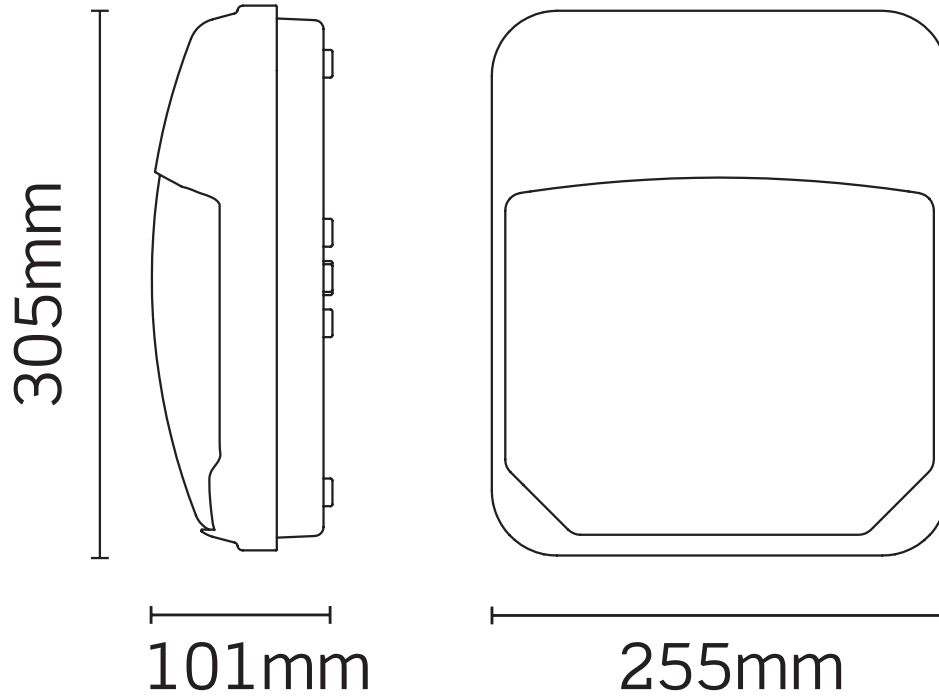

All dimensions in millimetres

You can help protect the environment. Please remember to respect the local regulations: hand in the non-working electrical equipment to an appropriate waste disposal centre. The packaging material is recyclable. Dispose of the packaging in an environmentally friendly manner and make it available for the recyclable material collection service.

Important warranty information

This product is supported by a 2-year standard warranty which will extend to 5-years if registered within the first year of purchase. (2 year on batteries). Please register at jcc.co.uk/warranty (Terms and conditions apply).

The installer will be asked to provide the following information, which is detailed on a label attached to the luminaire's chassis:
Product Code/Date Code.