

Toughbay™ Retrofit Range

Installation instructions for LED Highbay



WARNINGS AND CAUTIONS

- It is recommended that luminaires are installed by a qualified electrician to ensure the installation complies with the local current wiring regulations.
- Any broken or damaged parts should be replaced as soon as possible. JCC will not accept responsibility for claims arising from sub-standard installations.
- **Caution.** Risk of electric shock
- The external flexible cable or cord of this luminaire cannot be replaced; if the cord is damaged the luminaire shall be destroyed.
- These products are designed for connection to a 220-240V~ 50/60Hz supply.
- This luminaire is suitable for indoor and outdoor use.
- It may be necessary to upgrade your MCBs to allow for increased inrush current.
- This luminaire should be installed out of arms reach.
- Terminal block not included. Installation may require advice from a qualified person.
- It is recommended that the ambient room temperature should not exceed 60°C.

INSTALLATION

ENGLISH

Specifications Colour Temp: 4000K*/5700K Ra: 80

Wattage	Lumens	LpcW	Beam
100W	12300	123	60°/90°/120°
150W*	18400	123	60°/90°/120°
200W	24500	123	60°/90°/120°

Available finishes: Black only

Terminal block must comply to EN 60998-2-1 or EN 60998-2-2

Standard version connection

220-240V~ 50/60Hz / Class I

Figure 1. Mains input

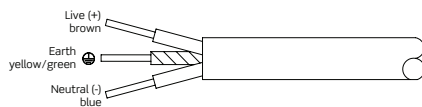

Emergency version connection

220-240V 50/60Hz / Class I

Figure 2.

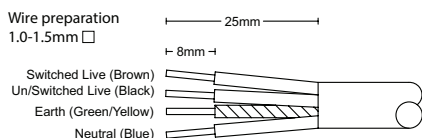

1-10V Dimming control input

Figure 3.

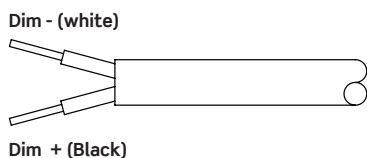

Accessories

JC040049* Surface Mount Bracket for 100/150/200W Toughbay Retrofit G2

*not suitable for EM and MW versions

- Read instructions and check that you have all of the tools and accessories required to complete the installation correctly. Isolate power supply before starting the installation.
- ### Standard dimmable version installation procedure
1. The luminaire comes with a fixed eye(s) for suspension as standard.
 2. For surface mounting please order correct bracket separately (see table below for details). Fit the bracket to a flat surface ensuring that fixings are suitable to hold the weight of the luminaire. Fit the luminaire to the bracket using the bolts supplied.
 3. Connect the mains input as shown in Fig.1, using a suitable connector to maintain the IP rating for the location.(not supplied). Please ensure that 3-core H07 RN-F cable is used.
 4. This luminaire is 1-10V dimmable as standard, if you wish to dim this fitting ensure that you connect the 1-10V dimming control wires as shown in Fig.3 to a 1-10V dimming system only. If no dimming is required please leave the terminals isolated.

Emergency dimmable version installation procedure

1. Follow steps 1-2 of the standard installation procedure.
2. Connect the mains input as shown in Fig.2, using the connector (supplied). Please ensure that 4-core H07 RN-F cable is used. To identify the correct terminals for mains input, unscrew/loosen the collar to expose the cables and match the connections to the corresponding colours in Fig.2
3. Once the mains supply is connected and the fitting is installed, connect batteries. The LED charge indicator will illuminate showing the fitting is in charge mode and is working correctly. Allow 24hrs for the batteries to charge prior to testing in emergency mode.
4. This luminaire is 1-10V dimmable as standard, if you wish to dim this fitting ensure that you connect the 1-10V dimming control wires as shown in Fig.3 to a 1-10V dimming system only. If no dimming is required please leave the terminals isolated.

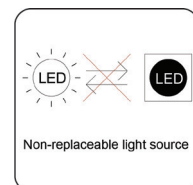
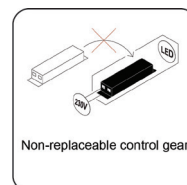

UK CA CE RoHS Compliant IP65 jcc.co.uk

You can help protect the environment. Please remember to respect the local regulations: hand in the non-working electrical equipment to an appropriate waste disposal centre. The packaging material is recyclable. Dispose of the packaging in an environmentally friendly manner and make it available for the recyclable material collection service.

Important warranty information

This product is supported by a 2-year standard warranty which will extend to 5-years if registered within the first year of purchase. (inc 1 year on site)
Please register at jcc.co.uk/warranty (Terms and conditions apply).

The installer will be asked to provide the following information, which is detailed on a label attached

BS EN ISO9001 - 2015 - Registered Firm Certificate No. GB 1552
JCC Lighting Products Ltd. Lux Park, Chichester Business Park, City Fields Way, Tangmere, Chichester, West Sussex, PO20 2FT
Technical Support: +44(0)1243 838986 Customer Services: +44(0)1243 838999

V11_Apr_2024_RS

Profile & Dimensions All dimensions in millimetres

100W

1-10V Dim

M/W Dim

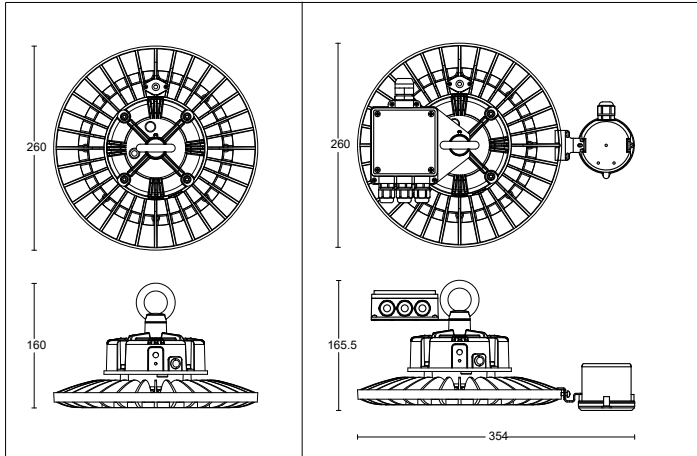

150W

1-10V Dim

M/W Dim

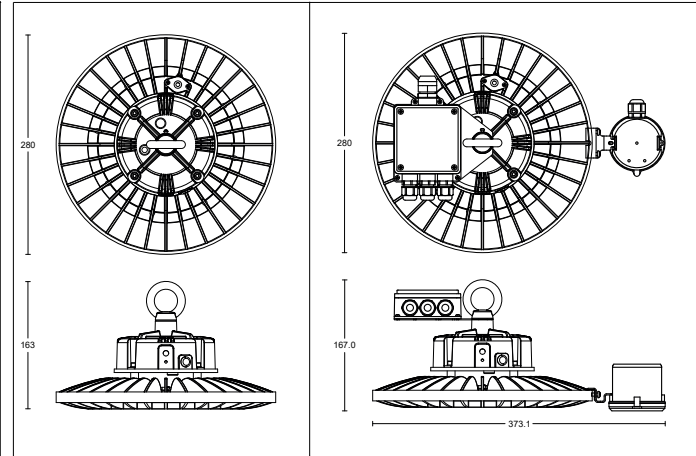

200W

1-10V Dim

M/W Dim

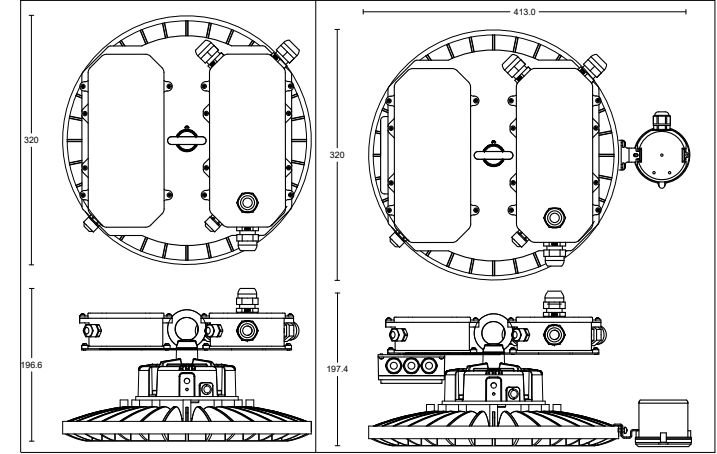
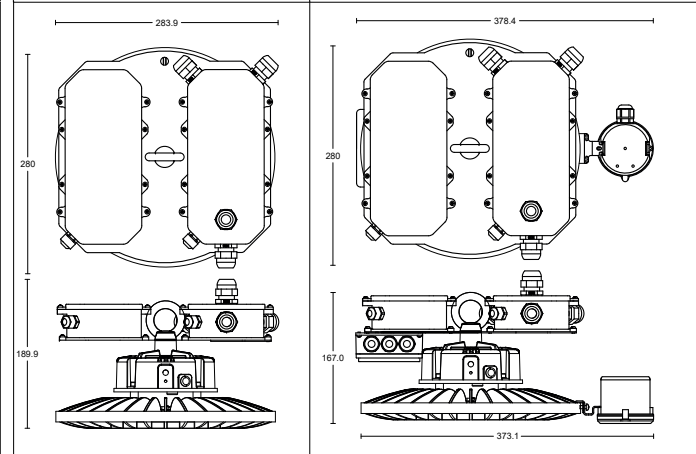
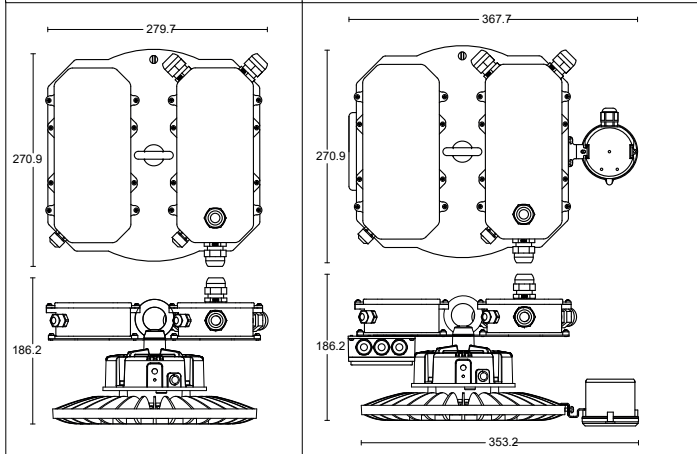
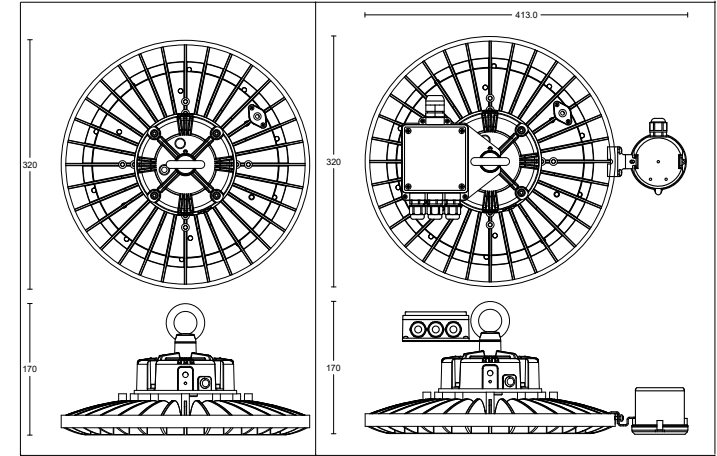

1-10V dim EM

M/W Dim EM

1-10V dim EM

M/W Dim EM

1-10V dim EM

M/W Dim EM

