

Mainline Track Range

Installation instructions for JC14093 3m suspension kit

JCC | a **LEVITON** company

Warnings & Cautions

- To avoid electric shock, serious injury or property damage, isolate power before installing, removing or servicing the product.
- It is recommended that this product is installed by a competent person to ensure the installation complies with the local current building regulations.
- Read instructions and check that you have all of the tools and accessories required to complete the installation correctly. Isolate power supply before starting the installation.
- JCC will not accept responsibility for claims arising from sub-standard installations; which will void the warranty.
- This product is suitable for indoor use only.

INSTALLATION

ENGLISH

Installation Procedure

The suspension kit is supplied with 3m cable which can be cut to the customers requirements.

1. Drill hole in suspended ceiling and fit ceiling plate and ceiling screw fix as shown in Fig. 1.
2. Screw suspension wire onto ceiling fix as shown in Fig. 2.
3. Place track fitting plate onto track as shown in Fig. 3, then twist 90° to locate into position as shown in Fig. 4.
4. Mains cable to be secured to suspension cable using cable ties as shown in Fig. 5.

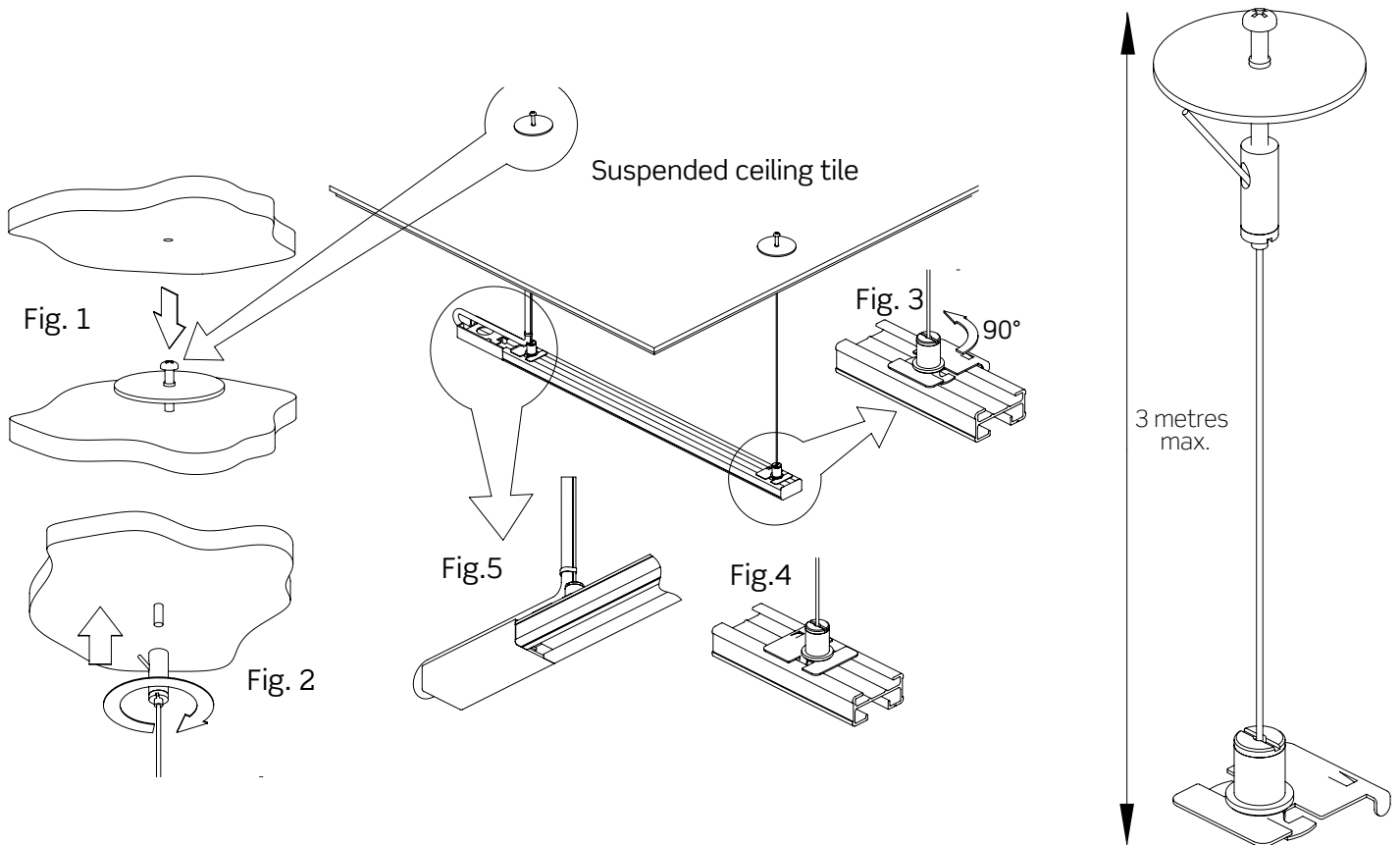

You can help protect the environment. Please remember to respect the local regulations: hand in the non-working electrical equipment to an appropriate waste disposal centre. The packaging material is recyclable. Dispose of the packaging in an environmentally friendly manner and make it available for the recyclable material collection service.

Important warranty information

This product is supported by a 2-year standard warranty. (See website for terms and conditions).



JCC.co.uk

BS EN ISO9001 - 2015 - Registered Firm Certificate No. GB 1552

JCC Lighting Products Ltd. Innovation Centre, Beeding Close, Southern Cross Trading Estate, Bognor Regis, West Sussex, PO22 9TS, United Kingdom

Technical Support: +44(0)1243 838986 Customer Services: +44(0)1243 838999

V5_Feb_2021_GL