

Mainline Track Range

Installation instructions for JC14094 3m wire suspension kit



Warnings & Cautions

- To avoid electric shock, serious injury or property damage, isolate power before installing, removing or servicing the product.
- It is recommended that this product is installed by a competent person to ensure the installation complies with the local current building regulations.
- Read instructions and check that you have all of the tools and accessories required to complete the installation correctly. Isolate power supply before starting the installation.
- JCC will not accept responsibility for claims arising from sub-standard installations; which will void the warranty.
- This product is suitable for indoor use only.

INSTALLATION

ENGLISH

Installation procedure

This product is designed to be used with the JCC Mainline Track System.

This system accessory is only suitable for indoor applications and must never be fitted to damp surfaces such as newly plastered or freshly painted ceilings.

It is recommended that thought be given to weight loading of the intended system layout. It is advisable to restrict the maximum distance between support cables to 1.5m. Care must be taken to ensure that all connecting track joints are secure and that if the track has been cut this has been done squarely and cleanly.

Note: Avoid mounting the suspended tracks in areas of strong air flow or near to ventilation systems.

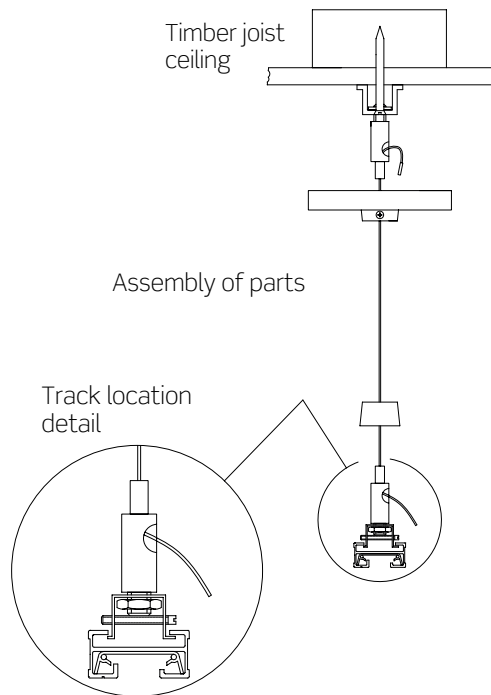

You can help protect the environment. Please remember to respect the local regulations: hand in the non-working electrical equipment to an appropriate waste disposal centre. The packaging material is recyclable. Dispose of the packaging in an environmentally friendly manner and make it available for the recyclable material collection service.

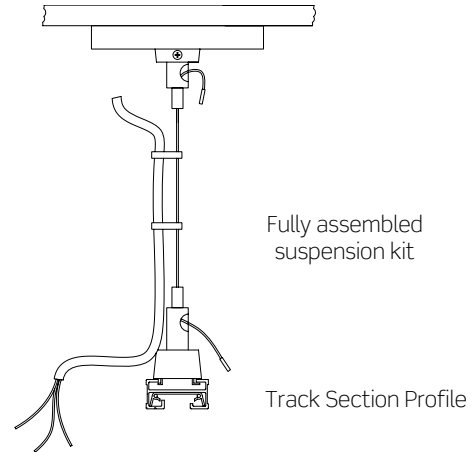

Breakdown of Parts

Anchorage Plate x1 + Mounting Screws x2

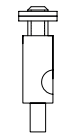

Adjustable Wire Locator
1 of 2

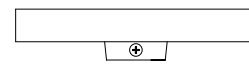

Ceiling Cover
x1

3m Suspension Wire
x1



Cable Clip
x8



Track Locator Cover
x1

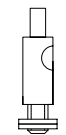

Adjustable Wire Locator
2 of 2



Track Locator Clip
x1

Important warranty information

This product is supported by a 2-year standard warranty. (See website for terms and conditions).



IP20 jcc.co.uk

BS EN ISO9001 - 2015 - Registered Firm Certificate No. GB 1552

JCC Lighting Products Ltd. Lux Park, Chichester Business Park, City Fields Way, Tangmere, Chichester, West Sussex, PO20 2FT

Technical Support: +44(0)1243 838986 Customer Services: +44(0)1243 838999

V6_Sept_2022_RS