

Mainline 3 Circuit Track Range

Installation instructions for JC88107 Mainline Three Circuit Track 'L' Connector
Right Side Earth



Warnings & Cautions

- To avoid electric shock, serious injury or property damage, isolate power before installing, removing or servicing the product.
- It is recommended that luminaires are installed by a qualified electrician to ensure the installation complies with the local current wiring regulations.
- JCC will not accept responsibility for claims arising from sub-standard installations; which will void the warranty.
- It may be necessary to upgrade your MCBs to allow for increased inrush current.
- Read instructions and check that you have all of the tools and accessories required to complete the installation correctly. Isolate power supply before starting the installation.
- This product is suitable for indoor use only.

INSTALLATION

ENGLISH

16 Amp max. per circuit Class I Ⓢ

Available in black and white

Installation procedure

Cutting Track

When reducing the length of track i.e. cutting down. It is recommended that a piece of masking tape be wrapped around the intended cutting area, this will ensure the powder coated or plated finish does not lift and chip. It is recommended for a good electrical connection that the installer should always mark out and cut track accurately using an engineers square prior to cutting.

Hint

Our recommendation would be to remove a section of material from the end of the track that is opposite to that of the 'L' connector. This would ensure a perfect connection and trouble free operation. Always ensure that the locking screw is tightened.

If you should experience any difficulties connecting Mainline 3 circuit components please check that they are correctly orientated. The locating channel inside the track will only allow the correct handed accessory to be inserted.

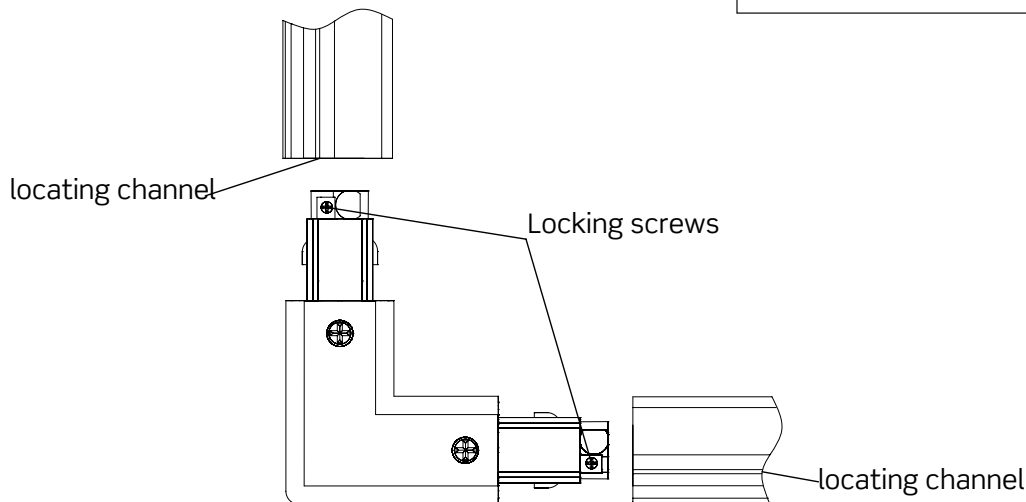
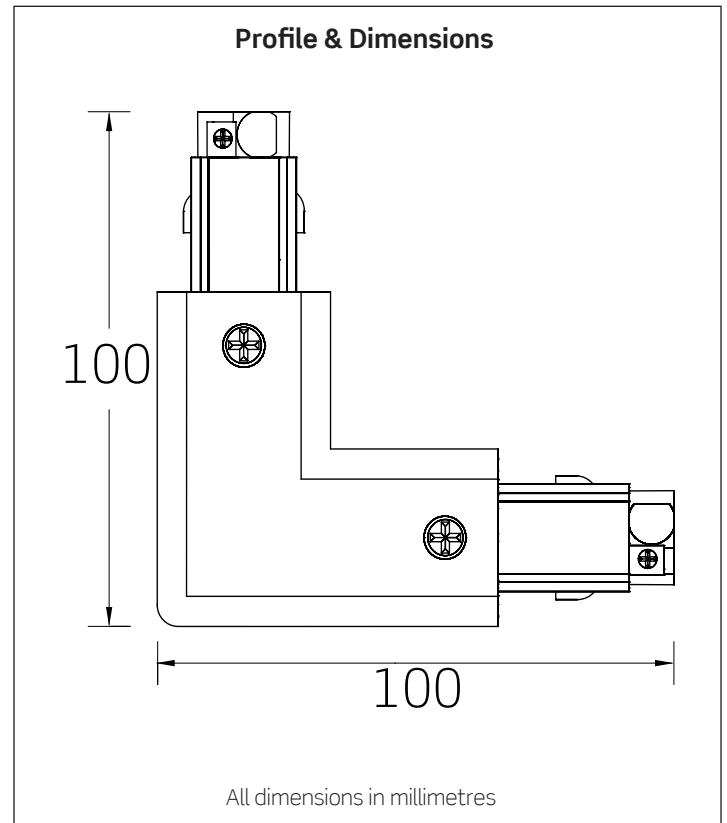

You can help protect the environment. Please remember to respect the local regulations: hand in the non-working electrical equipment to an appropriate waste disposal centre. The packaging material is recyclable. Dispose of the packaging in an environmentally friendly manner and make it available for the recyclable material collection service.

Important warranty information

This product is supported by a 2-year standard warranty. (See website for terms and conditions).

UK CA CE RoHS Compliant IP20 jcc.co.uk

BS EN ISO9001 - 2015 - Registered Firm Certificate No. GB 1552

JCC Lighting Products Ltd. Innovation Centre, Beeding Close, Southern Cross Trading Estate, Bognor Regis, West Sussex, PO22 9TS, United Kingdom

Technical Support: +44(0)1243 838986 Customer Services: +44(0)1243 838999

V2_Feb_2021_GL