

Mainline Track Range

Installation instructions for JC88115 Mainline 3 Circuit Track Wire Suspension Kit

JCC | a **LEVITON** company

Warnings & Cautions

- To avoid electric shock, serious injury or property damage, isolate power before installing, removing or servicing the product.
- It is recommended that this product is installed by a competent person to ensure the installation complies with the local current building regulations.
- Read instructions and check that you have all of the tools and accessories required to complete the installation correctly. Isolate power supply before starting the installation.
- JCC will not accept responsibility for claims arising from sub-standard installations; which will void the warranty.
- This product is suitable for indoor use only.

INSTALLATION

ENGLISH

Installation procedure

Cutting track

When reducing the length of track i.e. cutting down. It is recommended that a piece of masking tape be wrapped around the intended cutting area, this will ensure the powder coated or plated finish does not lift and chip. It is recommended for a good electrical connection the installer should always mark out and cut track accurately using an engineers square prior to cutting.

When installing the suspension kit it is advised to space them approximately 100mm from the end of the track section and repeat every 1 to 1.5 metres. If you should experience any difficulties connecting Mainline 3 circuit components, please check that they are correctly orientated. The locating channel inside the track will only allow the correct handed accessory to be inserted.

1. Feed suspension cable through the track bracket prior to fixing the bracket to the track section. Ensure that the track and track bracket are in the correct orientation as shown to the right. Locate one side into the bracket and rotate the track section into place and then secure with the locking plate and secure with the locking plate screw.

2. Once the bracket and cable have been fitted to the track section, place the cone shaped cover onto the cable as shown to the right.

3. Install the ceiling bracket using the fixing provided and then insert the cable retaining barrel and locking screw into the bottom of the ceiling bracket.

4. Feed the cable into the cable retaining barrel and adjust to desired length and then tighten the locking screw. Slide the cone shaped cover up to the top of the cable to cover the ceiling bracket and secure in place by tightening the retaining screw.

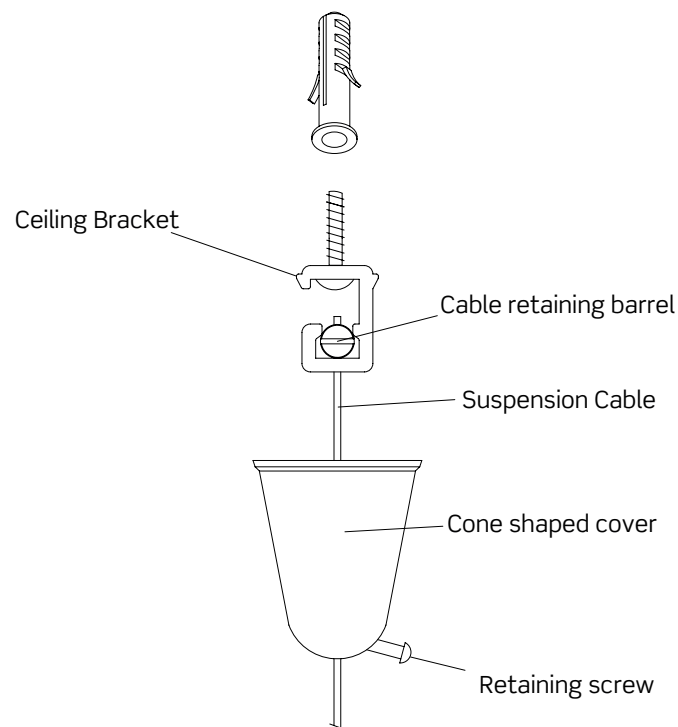
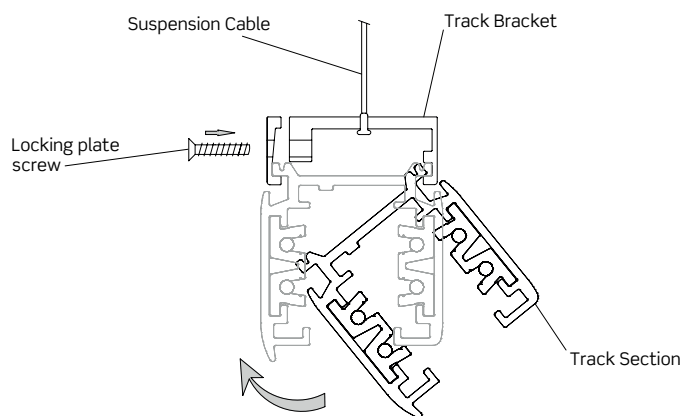

Profile & Dimensions

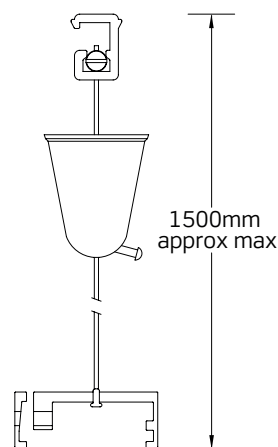

All dimensions in millimetres

You can help protect the environment. Please remember to respect the local regulations: hand in the non-working electrical equipment to an appropriate waste disposal centre. The packaging material is recyclable. Dispose of the packaging in an environmentally friendly manner and make it available for the recyclable material collection service.

UK CA CE RoHS Compliant IP20 **jcc.co.uk**

Important warranty information

This product is supported by a 2-year standard warranty. (See website for terms and conditions).

BS EN ISO9001 - 2015 - Registered Firm Certificate No. GB 1552

JCC Lighting Products Ltd. Innovation Centre, Beeding Close, Southern Cross Trading Estate, Bognor Regis, West Sussex, PO22 9TS, United Kingdom

Technical Support: +44(0)1243 838986 Customer Services: +44(0)1243 838999

V3_Feb_2021_GL