

# Starspot™ GU10 Single circuit

Installation instructions for GU10 Track Spotlight



## Warnings and cautions

- To avoid electric shock, serious injury or property damage, isolate power before installing, removing or servicing the product
- It is recommended that luminaires are installed by a qualified electrician and the installation complies with the local current wiring regulations
- It is recommended that the ambient room temperature should not exceed 30°C
- These products are designed for connection to a mains supply of 220-240V~ 50Hz
- This luminaire is suitable for indoor use only
- It may be necessary to upgrade your MCBs to allow for increased inrush current
- Do not carry out insulation tests with the product connected to the circuit
- Any broken or damaged parts should be replaced as soon as possible. JCC will not accept responsibility for claims arising from sub-standard installations

## INSTALLATION

ENGLISH

### Specification :

Mains supply 220-240V 50Hz / Class I

Available finishes: black or white

Lamp type: 7W max LED GU10 (lamp not supplied)

Product	Finish	IP
JC014230	White	IP20
JC014231	Black	IP20

Read the instructions and ensure that you have all of the tools and accessories required to complete the installation correctly. Isolate power supply before starting the installation.

### Installation

This product is to be used in conjunction with the JCC Mains Single Circuit Track System. The installation must not infringe on water pipes or any other electrical services. Locate fitting in track and rotate anti-clockwise, ensuring "P" polarity symbol is aligned correctly with track polarity. Observe minimum distance from nearest illuminated surface. Place lamps into lamholders. Once installed, turn on mains supply to test the luminaire.

Note: Further adjustment to the beam direction should be done with care as the lamps will get hot.

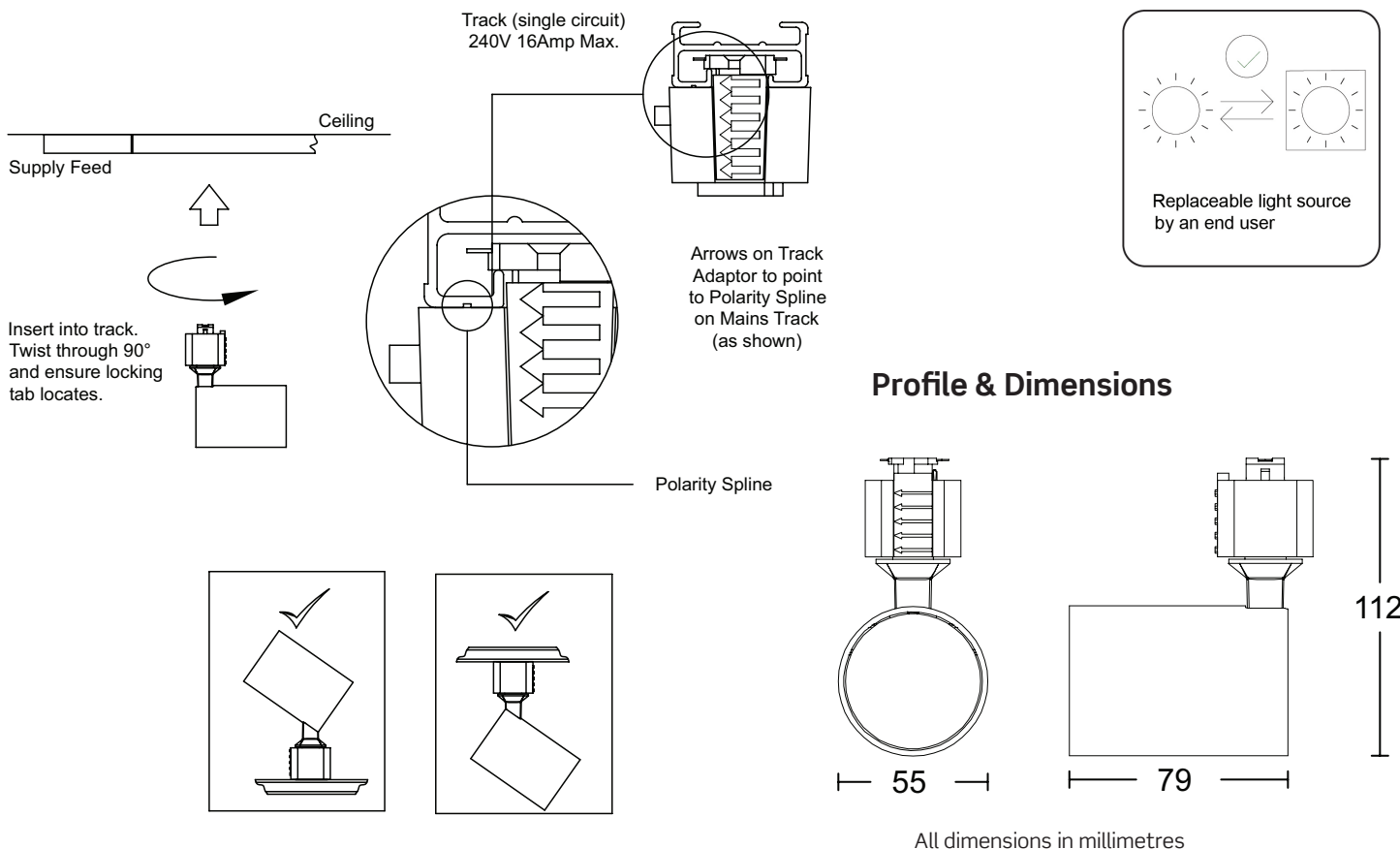

UK CA CE RoHS Compliant IP20 [jcc.co.uk](http://jcc.co.uk)

### Important warranty information

This product is supported by a 2-year standard warranty which will extend to 5-years if registered

BS EN ISO9001 - 2015 - Registered Firm Certificate No. GB 1552  
JCC Lighting Products Ltd. Lux Park, Chichester Business Park, City Fields Way, Tangmere, Chichester, West Sussex, PO20 2FT  
Technical Support: +44(0)1243 838986 Customer Services: +44(0)1243 838999

V1\_Nov\_2023\_RS

You can help protect the environment. Please remember to respect the local regulations: hand in the non-working electrical equipment to an appropriate waste disposal centre. The packaging material is recyclable. Dispose of the packaging in an environmentally friendly manner and make it available for the recyclable material collection service.