

# TIMEGUARD<sup>®</sup>

## LED Wide Beam PIR Floodlight



Model: LEDX20PIRBN (Black)  
Model: LEDX20PIRWHN (White)



Model: LEDX10PIRBN (Black)  
Model: LEDX10PIRWHN (White)



Model: LEDX30PIRBN (Black)  
Model: LEDX30PIRWHN (White)

Installation & Operating Instructions

# 1. General Information

These instructions should be read carefully and retained for further reference and maintenance.

## 2. Safety

- Before installation or maintenance, ensure the mains supply to the luminaire is switched off and the circuit supply fuses are removed or the circuit breaker turned off.
- It is recommended that a qualified electrician is consulted or used for the installation of this luminaire and install in accordance with the current IEE wiring and Building Regulations.
- Check that the total load on the circuit including when this luminaire is fitted does not exceed the rating of the circuit cable, fuse or circuit breaker.

## 3. Technical Specifications

- 230V AC, 50Hz
- These luminaires are of class I construction and must be earthed
- Energy Efficiency: Class E
- Colour Temperature: 4000K
- IP55 Rated suitable for restricted external applications
- Detection Angle: 180°
- Detection Range: Up to 12 metres
- Time On Adjustment: 5 seconds to 10 minutes
- Dusk Level Adjustment: Day and Night or Night only operation
- CE Compliant

### LEDX10PIRBN-WHN

- 10W LED Non replaceable lamp
- Energy Usage: 12Kwh/1000h
- Lumen Output: 1000lm

### LEDX20PIRBN-WHN

- 20W LED Non replaceable lamp
- Energy Usage: 21Kwh/1000h
- Lumen Output: 2000lm

## LEDX30PIRBN-WHN

- 30W LED Non replaceable lamp
- Energy Usage: 32Kwh/1000h
- Lumen Output: 3000lm

## Other Loads – External (Slave)

- Up to 10 sets of LEDX10-20-30FLN Standalone floodlights
- LED lamp: Max 10 sets with total of 200W
- Halogen lamp: Max 1000W
- Fluorescent: Max 15 sets 23W, or Max 345W
- Fluorescent tube w/o PF correction: Max 648W

## Parallel Switching

- A maximum of 4 LEDX10-20-30PIRN floodlights can be wired in parallel to enable any detector to turn ON all the lights connected.

# 2

## 4. Installation Advice

As the detector responds to changes in temperature, avoid the following situations:

- Pointing the detector towards objects with highly reflective surfaces, such as pools of water or white-painted walls.
- Mounting the detector near heat sources, such as heating vents, air conditioning units, lights etc.
- Pointing the detector towards objects that may move in the wind, such as curtains, tall plants etc.

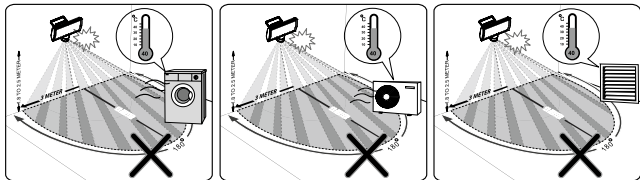

- Recommended installation height is 2.5m above ground, the maximum detection range about 12m and at the angle of about 180°

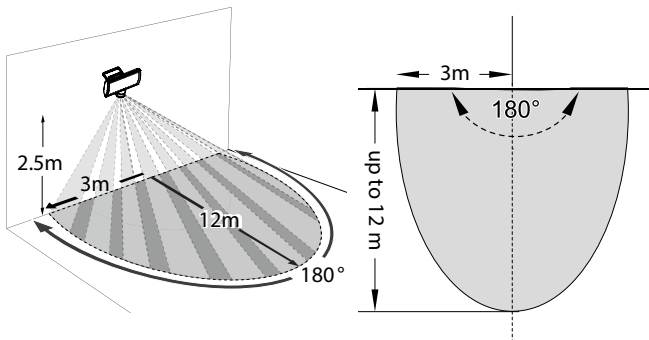

## 5. Installation Procedure

- 3
- 1 Mark the position of the mounting holes on the wall using the U bracket supplied as a template.

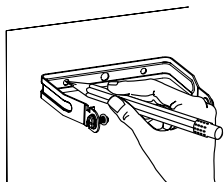

- 2 Drill the holes for the wall plugs ensuring not to infringe with any gas/water pipes or electrical cables that may be hidden below the surface.

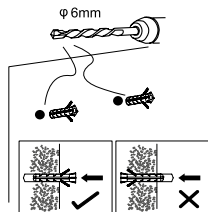

- 3 Fix the U bracket to the wall using the correct screws for the wall plugs installed.

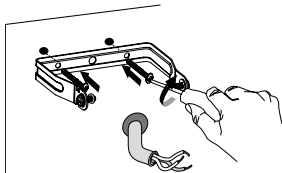

- 5.4 Secure the supply cable into the junction box through the hole(s) provided ensuring that a cable gland, grommet or sealing compound is used to maintain the IP rating of the luminaire.

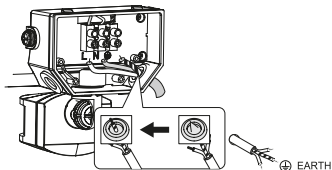

- 5.5 Attach the strain relief to the luminaire and screw in ensuring not to over-tighten.

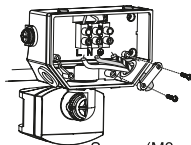

Screws: (M3 x 12mm) x 2

- 5.6 Terminate the supply cable into the terminal block (please refer to section 6 connection diagram) ensuring correct polarity is observed and that all bare conductors are sleeved.

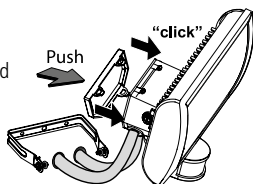

- 5.7 Attach the supplied wall plate to the luminaire, apply pressure to catches located on top and bottom until all click into place to ensure the weatherproof seal.

- 5.8 Attach the luminaire to the U bracket fitted to the wall, then screw in on both sides ensuring not to over-tighten.

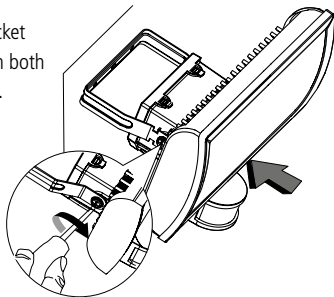

## 6. Connection Diagram

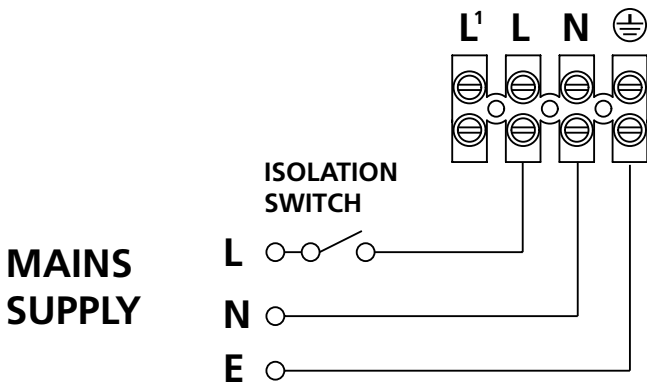

Connect the 3 core mains supply cable to the terminal block on the unit as follows:-

LIVE (Brown or Red)	L
NEUTRAL (Blue or Black)	N
EARTH (Green/Yellow)	⊕

**For additional lighting connect the external load to the terminal box on the back plate as follows;**

Connect the 3 core mains supply cable to the terminal block on the unit as follows:-

LIVE (Brown or Red)	L <sup>1</sup>
NEUTRAL (Blue or Black)	N
EARTH (Green/Yellow)	⊕

## 7. Operation

- Turn the power on to the isolating switch and test for correct operation.

## 8. Walk Test and Adjustment

- The purpose of the Walk is used to test and adjust the detection coverage of the floodlight under auto mode.

### Test Procedure

- Adjust the Time knob to (fully anti-clockwise), and Lux knob (can be set to 'Sun' or 'Moon').
- Switch the power On.
- Walk across the detection area, once the detector is triggered the lamp will turn ON for 2 seconds.

Note walking direction when performing test.

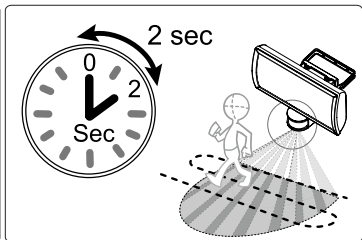
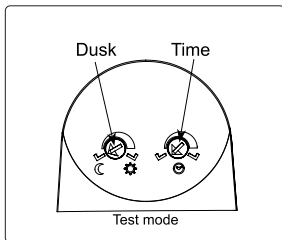

### Detector Head Adjustment

- The detector head can be turned 90° left or right by hand, and can be tilted 90° downward.
- Do not use the adjuster knobs to turn the detector head.

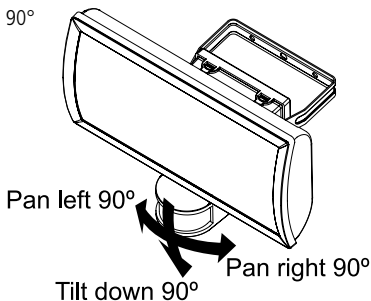

## Knob Settings

The floodlight has two adjustment knobs:

Time and Lux at the bottom of the detector head.

- Adjust the knobs carefully with flat blade screwdriver.

### TIME knob setting

- You can set the time knob from 5 seconds to about 10 minutes, the floodlight will switch the lamp ON, for the time duration set after each detected movement.
- Adjust the knob as desired.

### LUX knob setting

- When setting the Lux knob at 'MOON', the floodlight will only operate in the dark.
- When setting the Lux knob at 'SUN', the floodlight will operate in any light level.

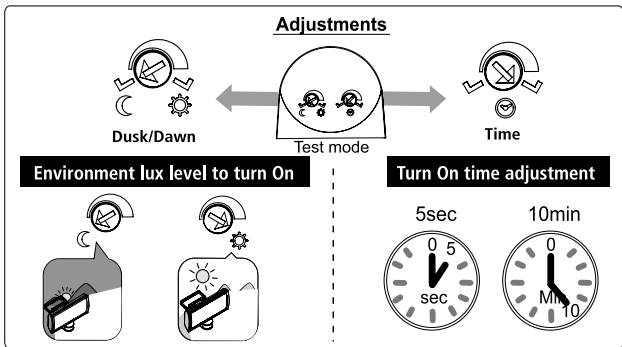



## Dusk setting (Time knob setting)

- When setting the Time knob to fully clock wise, the motion detector of the floodlight won't function.

The lamp will operate depending on the 'Lux' level, i.e. dusk to dawn.

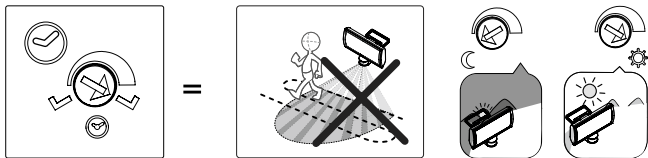

## Setting Advice

### WARNING

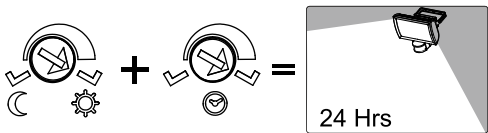

## 9. Lens Masking

- The purpose of the lens mask is to mask out areas not desired for detection.

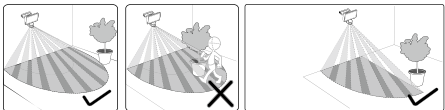

## Masking the Sensor Lens

- To restrict the sensor coverage, preventing detection in unwanted areas, mask the sensor lens using the masking label provided. The top section of the lens covers long range detection, the bottom covers short range. Similarly the left and right lens sections cover the left and right detection areas respectively.

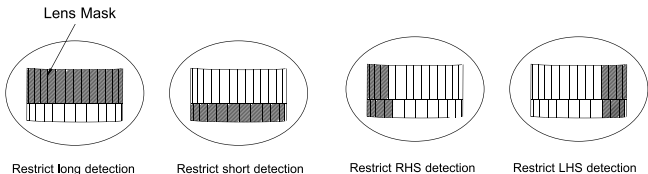

## 10. Manual Override Mode

The light can be switched on for longer time periods by use of the Manual Override Mode. This can be activated at night by using the internal wall switch or circuit breaker.

- Switch the internal wall switch/circuit breaker once (OFF/ON) within 1.5 seconds
- The unit will now illuminate continuously until dawn, or until switched back into Auto Mode
- To switch the unit back into Auto Mode, switch the internal wall switch/circuit breaker once (OFF/ON) within 1.5 seconds. The unit will operate as set up after the walk test procedure
- Note: The Manual Override Mode will not work if the floodlight is set into Test Mode (i.e. the Time Knob set fully clockwise)

## 11. Lamp Adjustment

- The lamp can be tilted upwards 45° and tilted downwards 60°

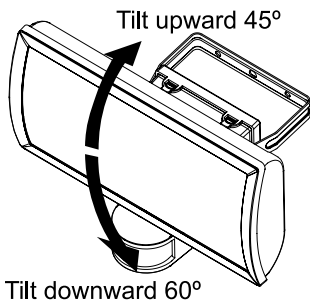

## 12. Troubleshooting Guide

Lamp stays ON all the time at night.

The unit may be suffering from false activation. Cover the sensor lens completely with a thick cloth. This will prevent the sensor from 'seeing' anything. If the unit now switches off after the set time duration and does not re-activate, this indicates that the problem was caused by false activation.

PIR keeps activating for no reason/ at random.

You may not be allowing the unit time to complete its warm-up period. Stand well out of the detection range and wait (the warm-up period should never exceed 5 minutes).

Occasionally, winds may activate the sensor. Sometimes passages between buildings etc. can cause a 'wind tunnel' effect.

Ensure the unit is not positioned so as to allow detection of cars/people using public thoroughfares adjacent to your property.

PIR sensor will not operate at all.

Check that the power is switched ON at the circuit breaker/internal wall switch.

Turn OFF the power to the unit and check the wiring connections as per the diagram. Ensure no connections are loose.

The PIR sensor will not operate at night.

The level of ambient light in the area may be too bright to allow operation at the current DUSK setting. During the hours of darkness, adjust the DUSK control slowly clockwise until the lamp illuminates. Refer to the previous section for more details.

Unit activates during the daytime.

The level of ambient light in the area may be too dark for the current DUSK setting. During daylight, adjust the DUSK control slightly anti-clockwise. When the lamp turns off, enter the detection area. If the PIR still activates, the setting is still too high. Repeat the above procedure until the PIR does not activate when you enter the detection area. Refer to the previous section for more details.

PIR coverage is poor/sporadic.

Unit may be poorly located. See previous section – ‘Selecting The Location’ and re-locate the unit.

Detection range varies from day to day.

PIR sensors are influenced by climatic conditions. The colder the ambient temperature, the more effective the sensor will be.

The floodlight will only activate for a maximum of 15 seconds when in normal operating mode.

The floodlight could be affected by its own light output. Tilt the PIR sensor further downwards and away from the floodlight. Once the floodlight has settled into the new time settings, re-angle the PIR sensor back to your desired position.

## 3 Year Guarantee

In the unlikely event of this product becoming faulty due to defective material or manufacture within 3 years of the date of purchase, please return it to your supplier in the first year with proof of purchase and it will be replaced free of charge. For years 2 and 3 or any difficulty in the first year, telephone the helpline on 020 8450 0515.

Note: A proof of purchase is required in all cases. For all eligible replacements (where agreed by Timeguard) the customer is responsible for all shipping/postage charges outside of the UK. All shipping costs are to be paid in advance before a replacement is sent.



If you experience problems, do not immediately return the unit to the store. Telephone the Timeguard Customer Helpline;

HELPLINE

**020 8450 0515**

or email [helpline@timeguard.com](mailto:helpline@timeguard.com)

Qualified Customer Support Co-ordinators will be on-line to assist in resolving your query.



**Deta Electrical Co Ltd**

Panattoni Park, Luton Road,  
Chalton, Bedfordshire, LU4 9TT

Sales Office: 020 8452 1112  
or email [csc@timeguard.com](mailto:csc@timeguard.com)

**[www.timeguard.com](http://www.timeguard.com)**