

# **TIMEGUARD®**

## Dedicated Photocell Professional

LEDPROPCB & LEDPROPCWH



Installation & Operating Instructions

## 1. General Information

These instructions should be read carefully and retained for further reference and maintenance.

## 2. Safety

- Before installation or maintenance, ensure that the mains supply to this system is switched off and the circuit supply fused are removed or the circuit breaker turned off.
- It is recommended that a qualified electrician is consulted or used for the installations of this system and install in accordance with the current IEE wiring and Building Regulations.
- Check that the total load on the circuit including when this system is fitted does not exceed the rating of the circuit cable, fuse or circuit breaker.

## 3. Technical Specifications

- 230V AC 50Hz
- Maximum Switchable Load: LED lamp - 147  
Halogen lamp - 7  
CFL - 200W  
Fluorescent tube w/o PF correction - 500W
- Time ON Adjustment: 2, 4, 6, 8 hours or Dusk to Dawn
- Dusk Level Adjustment: Day & night or night time only operation
- IP55 Rated suitable for restricted external applications
- CE Compliant

### Dimensions

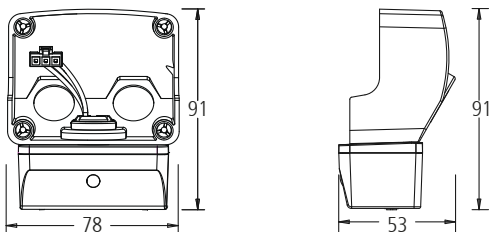

A

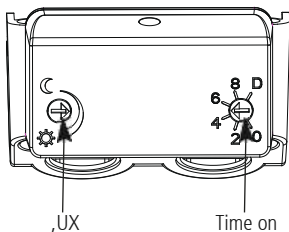

View on underside of unit shows adjustments

B

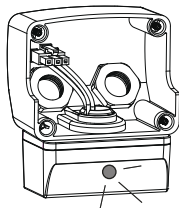

D

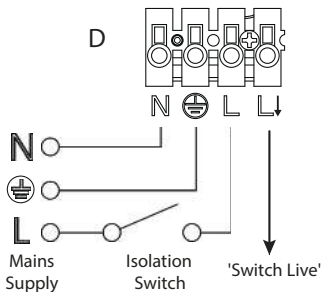

**Note:** Any floodlight connected to the L↓ Switch Live terminal 'Live Output' will be controlled by the Photocell

C

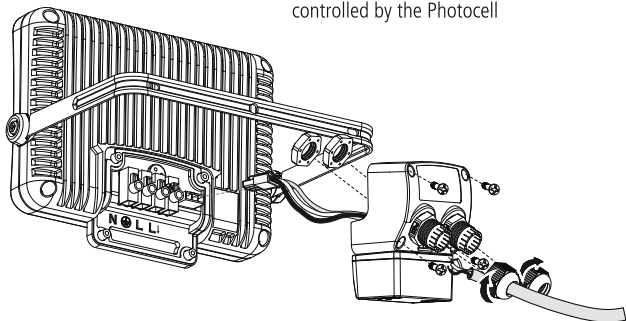

## 4. Installation

### \*\*\* IMPORTANT \*\*\*

Switch off the electricity at the fuse box by removing the relevant fuse or switching off the circuit breaker before proceeding with the installation.

- Remove the jumper plug from the floodlight.

#### Jumper Plug

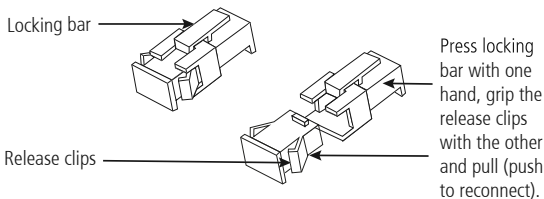

- Pass the mains supply and load cables through the holes provided on the Photocell ensuring that a cable gland, grommet or sealing compound is used to maintain the IP rating.

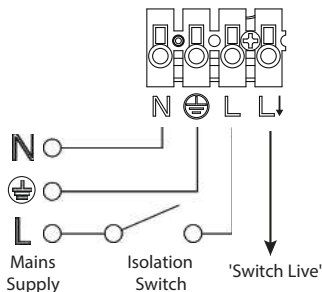

## CONNECTION

Connect the **mains supply cable** to the terminal block on the back plate as follows (see connection diagram):

EARTH (Green / Yellow)	⊕
NEUTRAL (Blue)	N
LIVE (Brown)	L

Connect the  **cable from the slave lighting load** to the terminal block on the backplate as follows (see connection diagram):

EARTH (Green/Yellow)	⊕
NEUTRAL (Blue)	N
SWITCH LIVE (Brown)	L↓

- Ensure that all connections are secure.
- Connect the 3 way Photocell plug, by pushing the plug and socket inside the floodlight together until they lock. **DO NOT FORCE. THE PLUG AND SOCKET WILL ONLY FIT TOGETHER ONE WAY AROUND** (See Jumper Plug diagram).
- Secure the Photocell to the luminaire using the 4 fixing screws supplied (see diagram C).

# 4

## 5. Operation and Testing

To Set the adjustment knobs as follows:-  
See diagram A.

Lux setting, fully clockwise (daylight setting)

The Lux setting determines at which light level the switch will turn its connected load "ON"

Turning this setting fully clockwise allows you to test the circuit during daylight.

Connect the photocell to the mains and switch power on.

After a short delay, the unit will switch ON. This is indicated by the red LED see diagram B. Any attached lights will also illuminate.

If you experience problems refer to Troubleshooting Guide.  
If problems still exist, do not immediately return the unit to  
store.

Telephone the Timeguard Customer Helpline

**020 8450 0515**

Qualified Customer Support Co-ordinators will be on-line to  
assist in  
resolving your query.

5

## 6. Troubleshooting

### PROBLEM

- ❑ The sensor will not operate at night.

### SOLUTION

The level of ambient light in the area may be too bright to allow operation at the current DUSK setting. During the hours of darkness, adjust the DUSK control slowly clockwise until the lamp illuminates. Refer to previous section for more details.

- ❑ Unit activates during the daytime.

Adjust the setting anti-clockwise to lower the level of ambient light required for activation.

## 3 Year Guarantee

In the unlikely event of this product becoming faulty due to defective material or manufacture within 3 years of the date of purchase, please return it to your supplier in the first year with proof of purchase and it will be replaced free of charge.

For years 2 and 3 or any difficulty in the first year, telephone the helpline on 020 8450 0515 .

Note: A proof of purchase is required in all cases. For all eligible replacements (where agreed by Timeguard) the customer is responsible for all shipping/postage charges outside of the UK. All shipping costs are to be paid in advance before a replacement is sent.



If you experience problems, do not immediately return the unit to the store. Telephone the Timeguard Customer Helpline;

**HELPLINE**

**020 8450 0515**

or email [helpline@timeguard.com](mailto:helpline@timeguard.com)

Qualified Customer Support Co-ordinators will be on-line to assist in resolving your query.



**Deta Electrical Co Ltd**

Panattoni Park, Luton Road,  
Chalton, Bedfordshire, LU4 9TT

Sales Office: 020 8452 1112  
or email [csc@timeguard.com](mailto:csc@timeguard.com)

**[www.timeguard.com](http://www.timeguard.com)**