

TIMEGUARD®

360° Surface Mount PIR
Presence Detector With
Optional Absence Detection

Model: PDSM361AB
(1 Channel)



Installation & Operating Instructions

1. General Information

These instructions should be read carefully and retained for further reference and maintenance.

Note: Timeguard reserve the right to alter these instructions at any time. Up to date instructions will always be available for download at www.timeguard.com

2. Safety

- Before installation or maintenance, ensure the mains supply to the PIR is switched off and the circuit supply fuses are removed or the circuit breaker turned off.
- It is recommended that a qualified electrician is consulted or used for the installation of this PIR and install in accordance with the current IEE wiring and Building Regulations.
- Check that the total load on the circuit including when this PIR is fitted does not exceed the rating of the circuit cable, fuse or circuit breaker.
- To clean use a clean dry cloth only. Do not use liquid cleaners.

3. Technical Specifications

- Mains Supply: 220-240V AC 50Hz
- Class Protection: Class 2
- IP Rating: IP54
- Operating Temperature: -20° to 40°C
- PIR Detection Range: up to 8m at a 2.5m mounting height
- Detection Angle: 360°

- Time ON Adjustment: 30sec - 30min
60 Minutes with optional remote control IR10AB
- (LUX) level adjustment: 10 - 2000
- Manual Override: Yes
- Load 1 for Lighting: 2200W Incandescent
2200W Halogen
1200VA/140uF Fluorescent
800VA/600W LED
- Modes: Presence / Absence

Note: Absence mode can only be triggered via using the IR10AB remote control. (Sold Separately). A push switch is required for absence mode to work on the PIR.

2

- CE Compliant
- EC Directives: Conforms to the latest directives
- Construction: Polycarbonate
- Dimensions (H x W x D): 105mm x 105mm x 48mm
- PIR Ceiling Projection: 48mm

If a 2 channel surface PIR is required, model number PDSMSB (Surface Mount Box), along with PDFM362AB (2 Channel Flush Mount PIR) can be combined to work as a 2 channel surface mount PIR. The flush and surface base plates are interchangeable. PDSMSB (Sold Separately)

4. Selecting a location

- The PIR has a number of detection zones at various horizontal and vertical angles as shown below.

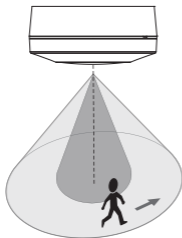

**Effective Approach Path
(ACROSS)**

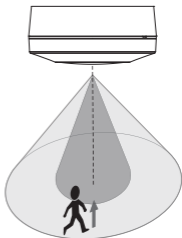

**Ineffective Approach Path
(TOWARDS)**

3

- A moving human body or object needs to cross one of these zones to activate the sensor. The optimum height for this is between 2m - 2.5m mounting height. Careful positioning of the luminaire is required to ensure the best performance from the PIR and the appointed approach path.
- Avoid positioning the PIR near any sources of heat in and around the detection area such as extractor fans, tumble dryers or boiler exhausts etc. This would also include other light sources such as security lights.
- Reflective surfaces (i.e. pools of water, white painted walls, overhanging branches and other types of foliage) may cause false activation under heightened weather conditions.

- During extreme weather conditions the PIR may exhibit unusual behaviour if placed in sight of a window. Once normal weather resumes, the PIR will carry out normal operations.

5. Installation

- Ensure the mains supply is switched off and the circuit supply fuses are removed or the circuit breaker turned off.
- An isolating switch should be installed to enable the power to be switched ON and OFF to the PIR. This allows the unit to be easily switched OFF for maintenance purposes.

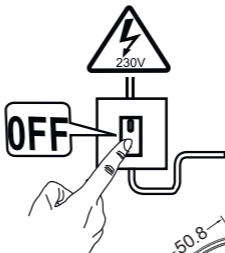

- Mark the position of the fitting holes using the base of the PIR as a template, taking care to avoid ceiling joists and other obstructions within the installation area.

Take note of the hole centres of the base plate for reference.

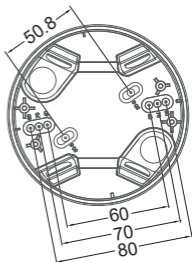

- Drill the holes and insert the rawl plugs into position.
- Pass the 230V 50Hz mains supply and load cables through the hole and prepare for termination.
- Knock out the most appropriate cable entry points on the base plate for the installation required.

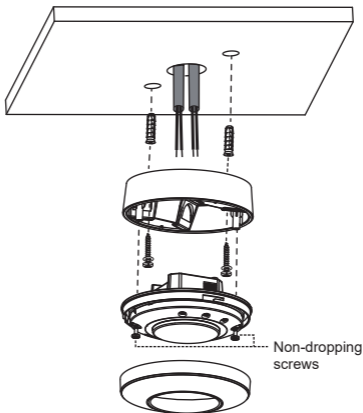

- Secure the base plate to the ceiling using the screws provided.

- Locate the terminal connections and terminate the cables into the terminal block ensuring that the correct polarity is observed and that all bare conductors are sleeved. (See Section 6. Connection Diagram)
- When wiring is complete, tighten the non-dropping screws shown in the above illustration to secure the PIR to the base plate and ensure not to over tighten.

6. Connection Diagram

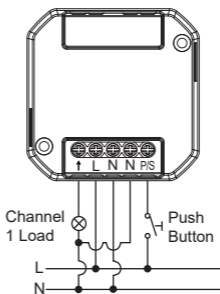

PDSM361AB: Wiring Configuration

230V AC 50Hz Mains Supply

Live (Brown or Red) to L

Neutral (Blue or Black) to N

Load

Switched Live

(Brown or Red) to ↑

Neutral (Blue or Black) to N

7. Commissioning and Operation

- Restore the power from the mains supply breaker or isolating switch and test for the correct operation.

Walk Test Procedure

- Adjust the time dial (fully anti-clockwise), and the Lux dial should be set to the sun symbol for daylight/night operation for the purpose of the walk test.
- Allow the PIR to settle down if the attached load is switched on, this is called warm up mode and can take several minutes to switch off as long as there is nothing detected in the pickup area.
- Once the unit is in the OFF position walk across the detection area, when the PIR is triggered and the load will turn ON for the minimum set amount of time.
- Once you are happy with the pickup area of the PIR you can set the Lux dial in the anticlockwise direction to trigger when dusk is approaching. (This may be best performed in real time in the evening subject to the users preference).
- You can also adjust the time dial which will vary the timeout periods of the PIR once the pickup area is vacated of any movement.

8. Switching from Presence to Absence mode

- The PIR will come pre-set to presence mode as standard, if you require an absence detector continue following this section. Note that a IR10AB remote will be required to change modes. Otherwise you can skip to section 9.

Switching From Presence To Absence Mode:

- To switch the PIR from presence to absence mode, press the **lock/unlock** button and you will see 2 flashes from the LED receiver of the PIR, this indicates that the PIR is unlocked and ready to receive further instructions from the remote control. Next press the **Semi Auto** button on the **IR10AB** remote control. The LED receiver light will flash once for up to 2 seconds and disappear, this indicates that the PIR is now in **Semi Auto** (absence mode).
- When the PIR set to absence mode, the unit will not switch on automatically when someone walks in the detection area.
- The person in the room must press the retractable push button for the light to switch on. From this point onwards as long as detection in the area has constant movement, the PIR will continue to keep the luminaire or attached load switched on, until the subject has moved out of the detection area and the time delay function takes over.
- For example if set to 10 minutes the PIR will begin to countdown from this value once nothing is in the detection area. If a subject is detected the time delay will reset.

Switching From Absence To Presence Mode:

- To switch the PIR from absence to presence mode, press the **lock/unlock** button and you will see 2 flashes from the LED receiver of the PIR. Next press the **Auto** button on the **IR10AB** remote control. The LED receiver light will flash twice and disappear, this indicates that the PIR is now in **Auto** (presence mode). There will be up to a 1 minute delay in changing modes where the PIR will not switch.

9. Optional Remote Control

- The IR10AB is an optional remote control that is sold separately. If absence detection is required the IR10AB will be needed to change modes over.



- LUX control adjustment. (Auto mode only).
- Time delay adjustment (up to 60 minutes Auto mode only).
- Independent channel control (PDFM362AB only).
- Sensitivity control.
- Manual override ON/OFF (10 hours).
- Learn mode: Set for a specific Lux level.
- Lock/Unlock PIR settings.
- Semi Auto mode: Absence
- Auto mode: Presence
- Pulse mode

9. Troubleshooting Guide

Problem	Cause/Solution
The luminaire does not switch on when in the detection area.	Bulb faulty or missing.
	Nearby light sources causing interference. Redirect the PIR or light source if possible.

Problem	Cause/Solution
False activation. (Luminaire switches on for no apparent reason)	Heat sources as described in section 4.
	Reflective surfaces described in section 4.
	Moving pedestrians, cars or animals in the area. Check the detection area.
	Nearby electromagnetic disturbance from a neighbouring circuit (CCTV interference).
Luminaire remains switched on	Continuous false activation resetting the delay time when an object is detected.
Luminaire switches on during daylight hours	Shadow casting over the PIR sensor
	Clouds creating a dark presence.
	Ensure the luminaire receives adequate daylight from all angles (not covered).

10

3 Year Guarantee

In the unlikely event of this product becoming faulty due to defective material or manufacture, within 3 years of the date of purchase, please return it to your supplier with proof of purchase and it will be replaced free of charge. For years 2 to 3 or with any difficulty in the first year, telephone our helpline. Note: a proof of purchase is required in all cases. For all eligible replacements (where agreed by Timeguard), the customer is responsible for all shipping/postage charges outside of the UK. All shipping costs are to be paid in advance before a replacement is sent.



If you experience problems, do not immediately return the unit to the store.

Email the Timeguard Customer Helpline:

HELPLINE

helpline@timeguard.com

or call the helpdesk on 020 8450 0515

Qualified Customer Support Coordinators will be online to assist in resolving your query.



A **theben** Group Company

For a product brochure please contact:

Timeguard Limited.

Victory Park 400 Edgware Road,
London NW2 6ND

Sales Office: 02084521112
or email csc@timeguard.com

www.timeguard.com

67.058.684 (Issue 1)