

TIMEGUARD[®]

100A Fused Switch Unit CUFMS100



Installation & Operating Instructions

1. General Information

These instructions should be read carefully in full before the installation, and retained for further reference and maintenance.

2. Safety

- Before installation or maintenance, ensure the mains supply to the switch unit is switched off and the circuit supply fuses are removed or the circuit breaker turned off.
- It is recommended that a qualified electrician is consulted or used for the installation of this switch unit and install in accordance with the current IEE wiring and Building Regulations.
- Check that the total load on the circuit including when this switch unit is fitted does not exceed the rating of the circuit cable, fuse or circuit breaker.
- After completion of the installation, it is essential that it is tested in accordance with the latest edition of the IEE Wiring and Building regulations for Electrical installations.

3. Technical Specifications

- Operating Voltage: 230V AC 50 Hz
This switch unit is of class I construction and must be earthed
- Fuses (IEC60269-2):
 - 100A HRC Fuse pre-fitted
 - 80A HRC Fuse supplied
- Switch Rating with 100A fitted (BSEN60947-3): 100A at 230V AC
- Switch Type: Double pole
- Maximum Cable Capacity: 35mm²
- Recommended Tightening Torque: 2.5Nm
- Mounting Centres: 98mm
- Operating Temperature: -10°C to +40°C
- IP20 Rated suitable for restricted internal applications
- CE Compliant
- Fused Switch Dimensions: H=78mm, W=120mm, D=64mm
- Cable Shroud Dimensions: H=52mm, W=80mm, D=45mm

4. Installation

- 4.1 Ensure the mains supply is switched OFF and the circuit supply fuses are removed or the circuit breaker turned OFF.
- 4.2 Ensure the black toggle switch on the front of unit is in the OFF position (upwards, so you can see the word OFF). in order for you to be able to remove the front cover.
- 4.3 Loosen the 2 fixing screws which hold the front cover in place.

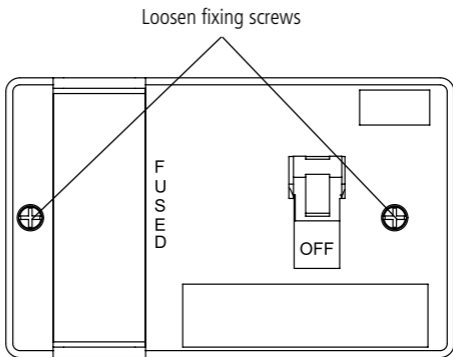

4.4 Lift the front cover off.

Note: The left hand fixing screw is longer than the right hand fixing screw.

4.5 Remove the fuse cartridge.

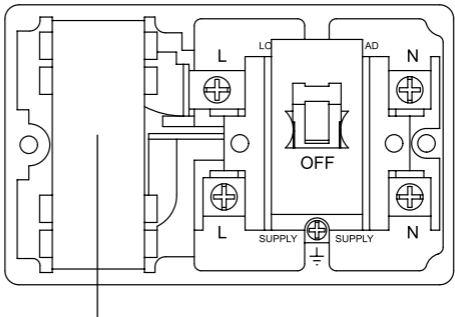

Fuse Cartridge (remove by gripping and pulling up and away from the fuse cartridge holder)

- 4.6 Mark the position of the mounting holes on the wall using the unit as a template, making sure you have the correct orientation – the fuse cartridge holder should be located on the left hand side, the black toggle switch should be on the right.

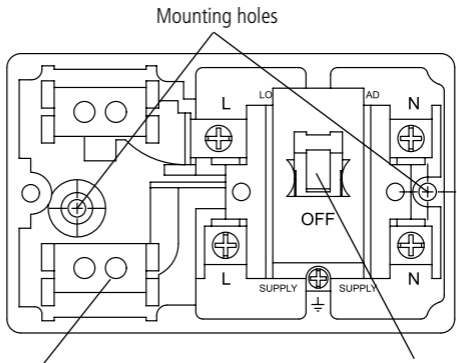

Fuse cartridge holder

Black toggle switch

- 4.7 Drill the holes ensuring not to infringe with any gas/water pipes or electrical cables that may be hidden below the surface, and insert the wall plugs.
- 4.8 Fix the unit to the wall using the correct mounting screws for the wall plugs installed.

Note: A cable shroud is supplied if you need to protect surface mounted cables. If required, mount this to the wall and feed the cables through the relevant holes (back or end cut-outs).

- 4.9 Prepare the 230V AC mains supply and load cables ready for termination (Mains supply cables to the bottom, Load }cables to the top). There is a pre-fitted black cover for the mains supply cable.
- 4.10 Connect the incoming supply and outgoing load cables to the relevant terminals ensuring correct polarity is observed and that all bare conductors are sleeved (see section 5. Connection Diagram).
- 4.11 Ensure all of the connections are tightened sufficiently.
- 4.12 Select the correct fuse for the installation, and plug the cartridge back into position.
- 4.13 There are cable entry and exit cut-outs located on the top (Load) and bottom (Supply) of the front cover, which will need to be removed according to the installation.
- 4.14 Once the correct cable entry and exit cut-outs have been removed, refit the front cover over the unit and secure using the short and long fixing screws.

5. Connection Diagram

- The terminals are marked as follows on the switch unit;

Load: Switch Live
(Brown or Red)

Load: Neutral
(Blue or Black)

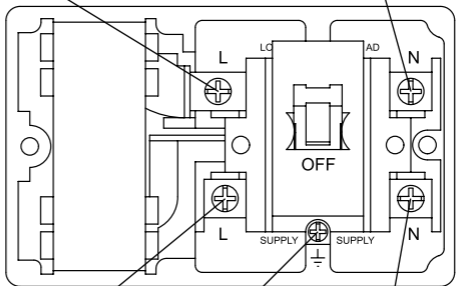

Earth (Yellow/green)

230V 50Hz Mains Supply:
Live (Brown or Red)

230V 50Hz Mains Supply:
Neutral (Blue or Black)

6. Support

Note: If you have any concerns that the intended application of this product does not meet your requirements, please contact Timeguard directly prior to installation.

3 Year Guarantee

In the unlikely event of this product becoming faulty due to defective material or manufacture, within 3 years of the date of purchase, please return it to your supplier in the first year with proof of purchase and it will be replaced free of charge. For years 2 to 3 or any difficulty in the first year, telephone our helpline.

Note: a proof of purchase is required in all cases. For all eligible replacements (where agreed by Timeguard) the customer is responsible for all shipping/postage charges outside of the UK. All shipping costs are to be paid in advance before a replacement is sent.



If you experience problems, do not immediately return the unit to the store. Telephone the Timeguard Customer Helpline;

HELPLINE
020 8450 0515

or email
helpline@timeguard.com

Qualified Customer Support Co-ordinators will be on-line to assist in resolving your query.



A **theben** Group Company

For a product brochure please contact:

Timeguard Limited.
Victory Park, 400 Edgware Road,
London NW2 6ND
Sales Office: 020 8452 1112
or email csc@timeguard.com

www.timeguard.com

67.058.656 (Issue 1)