

# **TIMEGUARD®**

## IP66 Wi-Fi Controlled Fused Spur Timeswitch

Model: FSTWIFITUTGV  
TuyaSmart Edition



Installation & Operating Instructions

# 1. General Information

These instructions should be read carefully and retained for further reference and maintenance.

**Note:** Timeguard reserve the right to alter these instructions at any time. Up to date instructions will always be available for download at [www.timeguard.com](http://www.timeguard.com)

## 2. Safety

- Before installation or maintenance, ensure the mains supply to the IP66 Wi-Fi fused spur is switched off and the circuit supply fuses are removed or the circuit breaker turned off.
- It is recommended that a qualified electrician is consulted or used for the installation of this IP66 Wi-Fi fused spur and install in accordance with the current IEE wiring and Building Regulations.
- Check that the total load on the circuit including when this IP66 Wi-Fi fused spur is fitted does not exceed the rating of the circuit cable, fuse or circuit breaker.
- To clean use a clean dry cloth only. Do not use liquid cleaners.

## 3. Technical Specifications

- Mains Supply: 220-240V AC 50Hz
- Class Protection: Class II
- IP Rating: IP66 (suitable for restricted external applications)
- Operating Temperature: 0° to 40°C
- Fused: Supplied with BS1362  
13A Fuse
- Rocker Switch: 2 Pole, providing isolation
- Contact Type: Normally Open, Micro Disconnection
- Wi-Fi Specification: 2.4GHz b/g/n only
- Frequency Range: 2.412 - 2.484 GHz

- Switch Rating: 13 A Resistive (3kW)  
1000W Incandescent, Halogen lighting  
500W Fluorescent, LED lighting.  
100W Compact Fluorescent lighting
- Operating Modes: ON or OFF, Timed, Countdown
- Output Light: Yes
- Multiple Device Support: Yes
- Dimensions (H x W x D): 160mm x 115mm x 90mm

**Note: Not suitable for use with Discharge Lighting.**

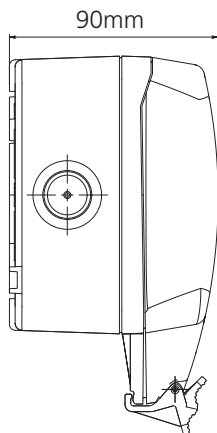
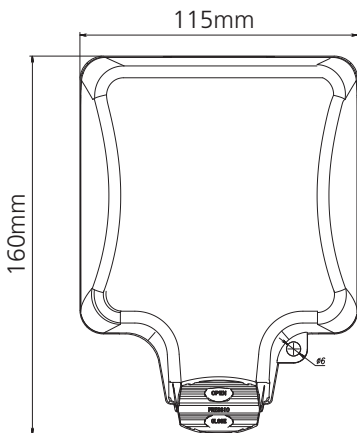

**FSTWIFITUTGV MAC address and ID Wi-Fi number label**  
Important: Do not remove this label from the side of the product.



**MAC: ACCXXXXXXXXXX** 160907

**ID WIFI: XXXXXXXXXXXX**

## 4. Operating Modes

**Timer:** Schedule ON/OFF periods as required. Programmes can be set individually for each day, or for every day of the week. Programs can be run either as a one off event, or a weekly repeat on days of your choice.

**Countdown:** Keeps the unit ON/OFF for a specific amount of time. (Countdown will reverse the state of the devices current status i.e. if the unit is switched ON the countdown will switch the unit OFF at the time given, and if the unit is switched OFF the countdown will switch the unit ON at the time given).

**Relay Status:** In the event of a power failure, once power is restored, the relay can be set to be in either the ON/OFF position by default or remember its last known position before the power went out.

## 5. System Requirements

- Smartphone/Tablet with at least iOS 9.0 or Android 6.0
- WLAN-enabled router: 2.4GHz (Separate Band)
- Tuya Smart App

## 6. Installation

- 6.1 Ensure the mains supply is switched off and the circuit supply fuses are removed or the circuit breaker is turned off.
- 6.2 Using a Phillips screwdriver, separate the faceplate from the back box by removing the four tapped screws located in each corner.

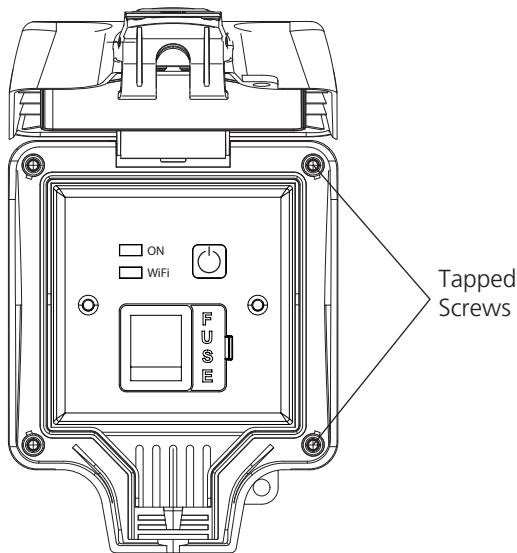

- 6.3 Using the back box as a template mark the position for the holes. Note the back box must be mounted in the correct orientation, following the 'TOP' marking inside the back box. If the mounting position desired is uneven use a sheet of marine ply as a base plate and fit the back box.

- 6.4 Drill the wall using a 4mm Ø drill bit making sure not to infringe or compromise any gas, water pipes or cables. Insert the rawl plugs into the holes. Secure the back box to the wall and seal the screw holes of the back box using the rubber plugs provided.
- 6.5 The drain feature must be drilled out using a 5mm drill bit if the top or side entry conduit is used. Opening this drain hole will reduce the IP rating of the product. Only the lower drain feature on the back box must be opened.
- 6.6 Select the required entry point and remove the knock out with a suitable holesaw. If conduit is not going to be used, a waterproof cable with suitable rated 20mm glands will be required to maintain the overall IP rating. If the bottom entry conduit is used, there must be adequate drainage from the lowest point of the conduit.
- 6.7 Secure the back box to the wall using suitable screws for the rawl plugs installed. Ensure that the back box is correctly orientated following the 'TOP' marking which is labelled inside.
- 6.8 Pass through the 230V AC 50Hz mains supply cable and secure the cables tightly to their respective terminals, ensuring that all bare conductors are sleeved and that correct polarity is observed. Connect the incoming earth to the the loop terminal on the FSTWIFITUTGV module. Note that if metal conduit is used the earth continuity between the conduits must be maintained.
- 6.9 Once the mains supply is connected to the correct terminals, mount the face plate to the four mounting holes on the back box. Tighten until secured. Seal the x4 face plate mounting screws using the x4 plastic caps provided.

**Note:** during the installation process, a suitable location should be selected to mitigate any Wi-Fi interference. Should the FSTWIFITUTGV and the wireless access point be located in an oversaturated area, where multiple devices and wireless equipment such as neighbouring Wi-Fi access points overlap, the device's connection may not perform as required.

## 7. Connection Diagram

**Note:** The earth must be connected for safety reasons

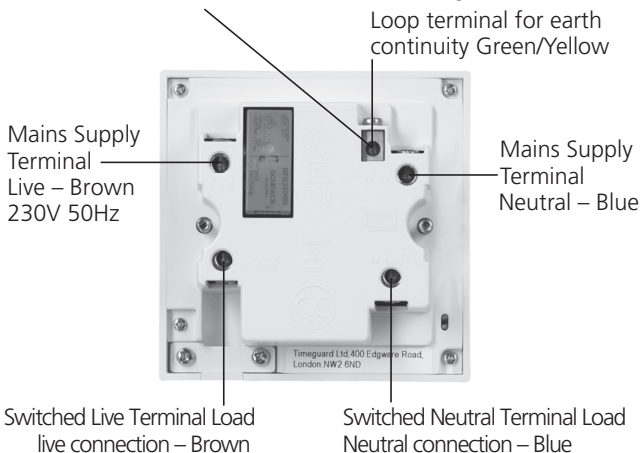

### Internal Schematic

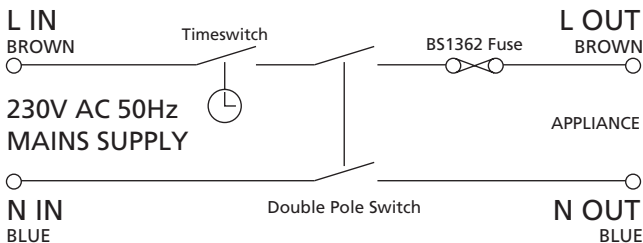

## 8. Downloading App & Registration

**Note: the mobile or tablet device must be connected to a 2.4GHz band on the router. Pairing on the 5GHz band will result in pairing timing out or being unsuccessful. Refer to your ISP (Internet Service Provider) on separating the bands if required.**

- 8.1 Ensure your phone or tablet is connected to your local Wi-Fi network.
- 8.2 Download the Tuya Smart App onto your phone or tablet by searching for 'Tuya Smart' on Google Play or the App Store. You can also scan the QR code below applicable to your device.



- 8.3 Install the App and open it to the registration screen. Click on the **'Register'** button.



- 8.3 Tap **'Agree'** to accept the privacy policy.
- 8.4 Choose your region by selecting your **'Country Code'**. Enter your email address and phone number and click **'Get Verification Code'**.
- 8.5 Enter the verification code sent to the email address or phone number that you provided. Once you have successfully entered the code, the app will automatically move you to the password screen.
- 8.6 Assign a password (this must be between 6 to 20 characters including letters and digits) and click **'Done'**. The App home page will now appear.

## 9. Pairing Your Device(s) Primary Method

**Note: if you are using a VPN, make sure this is disabled before continuing and ensure that a 2.4GHz Wi-Fi band is enabled for this device. This method requires bluetooth connectivity.**

- 9.1 Once you are on the home page of the Tuya Smart App, press and hold the pairing button on the FSTWIFITUTGV for 5 seconds, the Wi-Fi connection indicator will begin to flash rapidly.
- 9.2 If a message prompt stating **'Devices to be added'** has not been displayed on the app, press the plus button **'+'** on the top right hand side of the app.
- 9.3 The **'Devices to be added'** message prompt should now be visible showing the device to add to your account, press **'Go to add'** to proceed to the next step.
- 9.4 The **'Add device'** menu should display the FSTWIFITUTGV as a bluetooth device and already be ticked for adding to your account **'✓'**. Press the plus button **'+'** to move to entering the W-Fi password for the network your mobile or tablet is currently connected to and then press the **'confirm'** button to begin pairing.

9.5 Once the pairing process is complete, you can rename the device as required or press **'Done'** to finalise pairing.

**Note: if the pairing process was not successful, follow the bullet points from 'Section 9' to try again ensuring that the conditions for pairing have been met from the notes section.**

## 10. Pairing Your Device(s) Secondary Method

**Note: if you are using a VPN, make sure this is disabled before continuing and ensure that a 2.4GHz Wi-Fi band is enabled for this device. This method requires bluetooth connectivity.**

10.1 Once you are on the home page of the Tuya Smart App Press the plus button  on the top right hand side of the app.

10.2 Under the **'Add Manually'** menu, select the **'Electrical'** category on the left hand side of the app. Then select **'Switch (Wi-Fi)'** from the devices list.

10.3 Enter the W-Fi password for the network your mobile or tablet is currently connected to and then press the **'next'** button.

10.4 Press and hold the pairing button on the FSTWIFITUTGV for 5 seconds, the Wi-Fi connection indicator will begin to flash rapidly.

10.5 Select the **'Confirm the indicator is blinking rapidly'** option on the App, then press the 'next' button to begin the pairing process.

10.6 Shortly into the pairing process, the flashing Wi-Fi light will stop flashing and become stable. This indicates that the device has joined the network.

10.7 Once the pairing process is complete, you can rename the device as required or press **'Done'** to finalise pairing.

**Note: if the pairing process was not successful, follow the bullet points from 'Section 10' to try again ensuring that the conditions for pairing have been met.**

## 11. Smart Home Assistant

For Smart Home Assistant services such as Google Home or Amazon Alexa, follow the on-board instructions on the TuyaSmart App. This can be found under the '**Me**' section on the home page of the App.

**Note: The Smart Home Assistant services supported by the TuyaSmart App may change as it is a 3rd party App Service. Any services that may be removed are the responsibility of TuyaSmart developers and not Timeguard.**

## 12. Support

**Note: if you have any concerns that the intended application of this product does not meet your requirements, please contact Timeguard directly prior to purchase or installation.**

## 3 Year Guarantee

In the unlikely event of this product becoming faulty due to defective material or manufacture, within 3 years of the date of purchase, please return it to your supplier with proof of purchase and it will be replaced free of charge. For years 2 to 3 or with any difficulty in the first year, telephone our helpline. Note: a proof of purchase is required in all cases. For all eligible replacements (where agreed by Timeguard), the customer is responsible for all shipping/postage charges outside of the UK. All shipping costs are to be paid in advance before a replacement is sent.



If you experience problems, do not immediately return the unit to the store.

Email the Timeguard Customer Helpline:

**HELPLINE**

**helpline@timeguard.com**

or call the helpdesk on 020 8450 0515

Qualified Customer Support Coordinators will be online to assist in resolving your query.



A **theben** Group Company

For a product brochure please contact:

**Timeguard Limited.**

Victory Park 400 Edgware Road,  
London NW2 6ND

Sales Office: 02084521112  
or email [csc@timeguard.com](mailto:csc@timeguard.com)

**[www.timeguard.com](http://www.timeguard.com)**

67.058.689 (Issue 1)